

Grease separators



Grease disposal concepts

Grease separators

For full and partial disposal

For free-standing or ground installation

ACO. creating the future of drainage



The ACO system chain provides drainage solutions to meet tomorrow's environmental challenges

The increase in extreme weather conditions requires more complex approaches to water drainage. ACO provides smart system solutions which work in both directions: they protect people from water – and vice versa. Each ACO product within the ACO system chain sends the water in the right direction, so that it can be recycled in a way that makes sense both ecologically and economically. Within the ACO group it is ACO Building Drainage which supports the overall system chain, and combines system solutions for drainage, separation and pumping in order to create total drainage solutions for buildings.



collect:

Collect and store

- Floor drainage systems
- Bathroom drainage
- Roof drainage
- Multi-storey parking deck drainage
- Balcony and terrace
- Drainage pipe systems



clean:

Pre-clean and treat

- Grease separators
- Starch separators
- Light oil separators
- Process technology



hold:

Keep away from
and hold back

- Backflow systems



release:

Pump, drain and re-use

- Lifting plants
- Pumping stations



The ACO system
chain in action

Contents

Hygiene, safety and profitability	4
Products for every requirement	6
<hr/>	
Practical fields of application	9
<hr/>	
Technical information	15
Principles and function	16
Grease separators for partial disposal	17
Grease separators for full disposal	18
Product benefits: materials and shapes	19
Product benefits: the ACO extension stage system	20
Planning notes	21
Pumping stations	24
GSM module	24
Odour neutraliser	25
Waste water treatment	25
<hr/>	
Product overview of ACO grease separators	27
Full disposal	
Below ground installation	28
Free-standing installation	37
Mobile solution	60
Partial disposal	
Free-standing installation	62
<hr/>	
Supplementary components	68
<hr/>	
Process optimisation of ACO grease separator plants	75
Lipufloc dosing station	76
Odour neutraliser	77
<hr/>	
Lifting plants	79
Lifting plants for installation downstream of grease separators	80
<hr/>	
ACO service chain	84

Hygiene, safety and profitability – thanks to ACO drainage solutions

As one of the world's leading drainage specialists, the ACO Group understands the critical role that drainage has to play in commercial kitchens. We know that hygiene, safety and profitability are important factors, but understand nevertheless that, for many, drainage is not a key focus. As a result of this, a lot of drainage systems are not planned in full, which in the best-case scenario will lead to expensive maintenance work, and in the worst case – if food becomes contaminated – to the facility's closure.

As the company which defines itself as "The future of drainage", it is our duty to really get involved in these fields, as well as to redevelop standards throughout the entire drainage process chain.

Our HygieneFirst philosophy is not only a commitment to hygiene, but covers other aspects too. Which is why we are developing intelligent drainage solutions that are also setting new standards in terms of safety and profitability.

Hygiene

Hygiene standards in commercial kitchens are getting more stringent all the time. ACO has taken on this challenge and come up with drainage solutions specifically tailored to these needs. In developing the new range of box channels, attention has been paid to the requirement for hygienic design. With this range, we are setting a new hygiene standard for drainage solutions.

Safety

Minimising the risk of injury is of paramount importance when it comes to fitting out workplaces. Safety is writ particularly large in commercial kitchens, as work needs to be performed quickly and safely. Another essential safety aspect is fire protection and ACO drainage systems made of stainless steel meet all requirements in this regard.

Profitability

Cost pressure during the planning phase and efficiency improvements during day-to-day operation only seemingly contradict each other. Cleaning foul air traps, floor gullies and box channels quickly, effectively and safely reduces running costs. Connecting the floor to the drainage systems permanently and with no leaks minimises maintenance costs.

The integrated ACO product range of **drainage systems to grease separators** right up to **wet waste collecting systems** provides the technical equipment you need to secure hygienic, safe and profitable operating workflows whilst at the same time complying with all technical standards.

HygieneFirst – the benefits of separator technology

ACO offers a comprehensive range of step increases in nominal sizes for dimensioning grease separators, both those for free-standing installation and those for below ground installation. This means the perfect solution can be provided according to the level of waste water to be dealt with; there is no need to take the next highest nominal size for reasons of capacity, which saves money and space.

In order to reduce microbes, very hot water is used for rinsing in hospitals, catering facilities and homes for senior citizens in particular, with the separator logically being exposed to that same water. The same applies to the emptying of tilting frying pans and boilers.

Grease separators made of stainless steel are ideally suited to such tasks, in order to prevent deformations in the long run. Stainless steel belongs to building material class A1, so does not represent any fire load or fire hazard. A planner should aim to reduce the fire load in a building as far as possible and guarantee high safety standards.

Furthermore, irrespective of the material, a large selection of extension stages are available, each of which can increase operational and cleaning safety. This is achieved by additional components such as systems for inner cleaning, as well as filling devices and disposal pumps. Measuring devices are also able to monitor operating conditions and reliably forward them to corresponding monitoring devices.

Hygiene

- Plants available in stainless steel
- Effective inner cleaning to remove all residue in the separator
- Homogenising and cleaning in a single step
- Hydro-mechanic high-pressure inner cleaning (175 bar, 360°)
- Neutralisation of odours
- Cover can remain closed during inner cleaning

Safety

- Plan with certainty, thanks to a huge choice of materials
- Solutions for all types of construction
- No additional fire load introduced to the building thanks to the use of stainless steel (building material class A1)

Profitability

- Disposal to meet your requirements by measuring the grease layer
- Fast troubleshooting, thanks to GSM module
- One module for all ACO products
- Avoidance of the heavy polluter surcharge



High-pressure inner cleaning of a grease separator for disposal leaving no residue



Odour neutraliser for a grease separator (basic model, extension stage 1)

ACO grease separators – products for every requirement



Food preparation

Whilst cleaning pans, dishes and other kitchen equipment units in commercial kitchens, a great deal of waste water containing grease or fat is produced, which cannot be fed into the sewage system just like that.

This primarily applies to hotels, university refectories, canteens, service stations and hospitals, as well as cafeterias in shopping centres and large kitchens which grill, roast and fry.



Factories producing meat

When slaughtering and dismembering animals, as well as processing them into meat and sausage products, large amounts of waste water still with a very high grease content are created. This could add up to several tons per day, depending on the

particular production processes used in the factory and the grease has to be removed from this waste water accordingly. Besides meat and sausage factories, this primarily applies to slaughterhouses and butchers.



Food industry

Due to the production processes used in various food industries, waste water containing animal and vegetable fats that can be retained may arise during food manufacture.

This could be the case, for example, in edible oil refineries, peanut roasters and factories producing crisps and chips.



Materials and shapes for every building situation

ACO grease separators are made from polyethylene or stainless steel. Polyethylene is characterised, for instance, by its lightweight construction and long lifetime, whilst stainless steel also offers high temperature resistance. By choosing the shape

that best fits the building project (e.g. round, oval or split), grease separators can be easily retrofitted into buildings during renovation work, for example. Unusual conditions can be dealt with by means of special constructions and site welds.

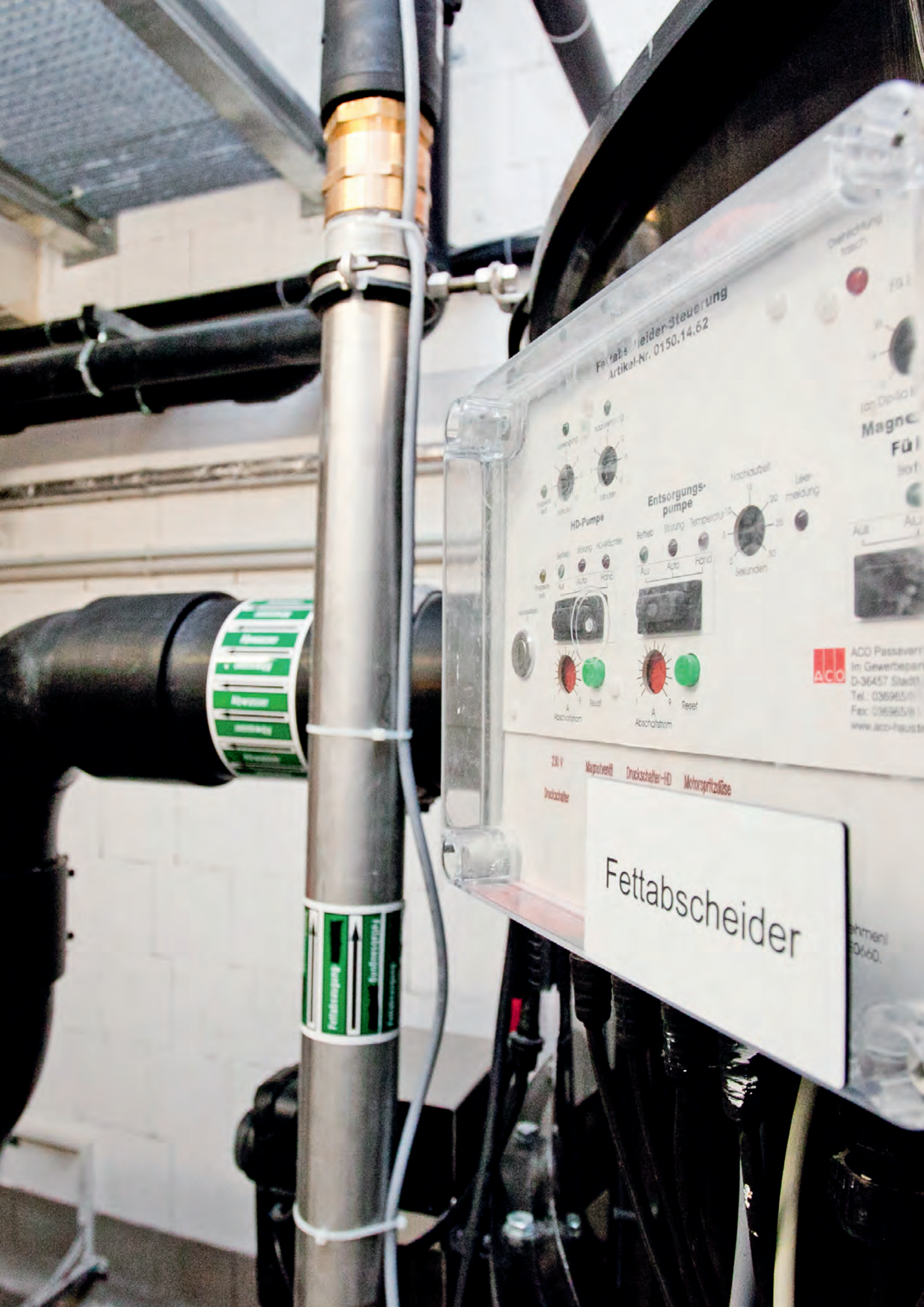

Fettabscheider-Steuerung
Artikel-Nr. 0150.14.62

HD-Pumpe

Stopfung
Nachlaufzeit

Minuten

HD-Pumpe
Betrieb Störung HD-Drucke

Auto Hand

HD-Drucke

Entsorgungspumpe

Nachlaufzeit

Leermeldung

0 10 20 30 60 Sekunden

Betrieb Störung Temperatur

Auto Hand

ACO

ACO Passiver
In Gewerbebetrieb
D-36457 Stadtl.
Tel.: 036965111
Fax: 036965111
www.aco-haustechnik.de

230 V
Nagelventil Druckschalter-HD Motorspritzdüse
Druckschalter

Fettabscheider

Druck
Druck
Druck
Druck

Fettabsaugung
Druckabsaugung

Practical fields of application

for grease separator plants

Grease separators are used wherever animal or vegetable fats are carried into waste water. Different separators are available for the various applications found in the field, which are manufactured specifically for particular requirements or building situations, whether they are found in new buildings or renovation projects.

ACO provides grease separator systems as a complete solution for a range of application areas, from snack bars right up to industrial food production.

Practical fields of application

Application examples





Restaurant requirements (new buildings)

- Simple installation
- Possibility of odour-free disposal
- Low maintenance costs
- Short distance between grease separator and disposal vehicle

ACO system benefits

- Separator material: polyethylene
- No formation of noxious smells, as cleaning performed via direct suction
- Simple checking of grease layer thickness
- Optional upgrade to a higher extension stage via ACO Service

Product recommendations

Grease separator	Mandatory system components	Optional system components	Lifting plant
<p>LipuJet-P-OD</p>  <ul style="list-style-type: none"> ■ Extension stage 1 ■ Full disposal ■ Free-standing installation 	<p>Sampling pot</p> 	<p>Odour neutraliser</p> 	<p>Muli-Mini duo</p> 





Restaurant requirements (renovations)

- Maximum volume flow up to 4 l/s
- Grease separator can be split for difficult access openings
- Possibility of odour-free disposal
- Low maintenance costs
- Short distance between grease separator and disposal vehicle

ACO system benefits

- Separator material: polyethylene
- Easy to transport and assemble
- Split into three parts to facilitate bringing-in to the installation premises

Product recommendations

Grease separator	Mandatory system components	Optional system components	Lifting plant
<p>LipuJet-P-SD</p>  <ul style="list-style-type: none"> ■ Extension stage 1 ■ Full disposal ■ Free-standing installation 	<p>Sampling pot</p> 	<p>Odour neutraliser</p> 	<p>Muli-Mini duo</p> 





Hospital requirements

- Odour-free disposal and cleaning
- Little staffing required for disposal
- Reduction in the fire load
- Segment design for difficult access situations

ACO system benefits

- Separator material: stainless steel (material grade 316)
- Programmed, odour-free disposal/cleaning
- Option to retrofit disposal pump
- Systems designed for integration minimise the staffing required

Product recommendations

Grease separator	Mandatory system components	Optional system components	Lifting plant
<p>LipuJet-S-RA</p>  <ul style="list-style-type: none"> ■ Extension stage 3 ■ Full disposal ■ Free-standing installation 	<p>Sampling pot</p> 	<p>Remote control, GSM module and measuring equipment for grease layer thickness</p> 	<p>Muli-Pro</p> 





Hotel requirements

- Odour-free disposal and cleaning
- Long distances between grease separator and disposal vehicle
- Little staffing required for disposal

ACO system benefits

- Separator material: polyethylene
- Programmed, odour-free disposal/cleaning
- Systems designed for integration minimise the staffing required

Product recommendations

Grease separator	Mandatory system components	Optional system components	Lifting plant
<p>LipuJet-P-OAP</p>  <ul style="list-style-type: none"> ■ Extension stage 3 ■ Full disposal ■ Free-standing installation 	<p>Sampling pot</p> 	<p>Remote control and measuring equipment for grease layer thickness</p> 	<p>Muli-Star DDP</p> 

Practical fields of application





Works kitchen/university refectory requirements

- Separator installed below ground
- Odour-free disposal and cleaning
- Load class A 15 – D 400

ACO system benefits

- Separator material: polyethylene
- Calculated tank statics for 50 years
- Maximum protection against upwelling without additional in-situ work for load class D 400
- Systems designed for integration minimise the staffing required
- Pumping station available with a variety of accessories

Product recommendations

Grease separator	Mandatory system components	Optional system components	Pumping station
<p>LipuMax-P-DM</p>  <ul style="list-style-type: none"> ■ Extension stage 2 ■ Full disposal ■ Below ground installation 	<p>Sampling shaft</p> 	<p>Measuring equipment for grease layer thickness and GSM module</p> 	<p>Powerlift-P</p> 





Butcher's requirements

- Grease separator installed below ground
- Waste water from slaughterhouse
- Load class A 15 – D 200

ACO system benefits

- Separator material: polyethylene
- Calculated tank statics for 50 years
- Maximum protection against buoyancy without additional in-situ work for load class D 400
- Systems designed for integration minimise the staffing required
- Pumping station available with a variety of accessories

Product recommendations

Grease separator	Mandatory system components	Optional system components	Pumping station
<p>LipuMax-P</p>  <ul style="list-style-type: none"> ■ Basic model ■ Full disposal ■ Below ground installation 	<p>Sampling shaft</p> 	<p>Grease level sensor</p> 	<p>Muli-Max-F duo</p> 

Snack bar requirements

- Mobile use
- Daily disposal of the contents of the grease separator

ACO system benefits

- Separator material: polyethylene or stainless steel (material grade 316)
- Easy to erect thanks to low weight and compact dimensions
- Odour-proof manhole cover
- Simple emptying and cleaning
- Flexible connection options

Product recommendations

Grease separator		
<p>Lipumobil-P 0.3</p>  <p>■ Mobile use</p>	<p>Lipumobil-P 0.5</p>  <p>■ Mobile use</p>	<p>Lipumobil-S 0.3</p>  <p>■ Mobile use</p>

Requirements of a mountain restaurant with no access for disposal vehicles

- No access for disposal vehicles
- Operating personnel available for handling grease and sludge drums

ACO system benefits

- Separator material: stainless steel (material grade 316)
- No disposal vehicle needed – grease and sludge are collected in changeable drums
- No grease deposits, as precipitated substances only remain in the separator for a short while
- Disposal: no need to interrupt operation of the catering establishment

Product recommendations

Grease separator	Mandatory system components	Optional system components
<p>Lipator-S-RA</p>  <p>■ Partial disposal ■ Free-standing installation</p>	<p>Sampling pot</p> 	<p>Coarse trap</p> 



Technical information

on grease separator plants

Industries generating waste water must have pre-treatment plants to ensure that solids and liquids that release harmful and unpleasant vapours, attack building materials and drainage installations or interfere with operations, are not discharged into public pipelines.

In businesses which generate waste water containing grease or fat, grease separators in accordance with EN 1825 must be installed in order to retain organic fats and oils from the grey water. This applies, for example, to catering and meat processing establishments.

Principles and function

A grease separator works purely physically, applying gravity (difference in density), i.e. heavy waste water contents sink to the bottom and light substances such as animal oils and fats rise to the top of the separator.

The grease layer can be broken down in a targeted manner using the high-pressure jet of up to 175 bar from the special

rotating cleaning head and homogenised so it is ready to destroy. Depending on the location situation, the contents of the separator can be sucked out by the disposal vehicle via permanently installed local piping or conveyed too using an optional disposal pump.

Operating principle for full disposal/free-standing installation

With grease separators for full disposal, sludge and grease are collected in the separator container installed in the building and picked up by a disposal contractor at certain intervals or as required.

Video

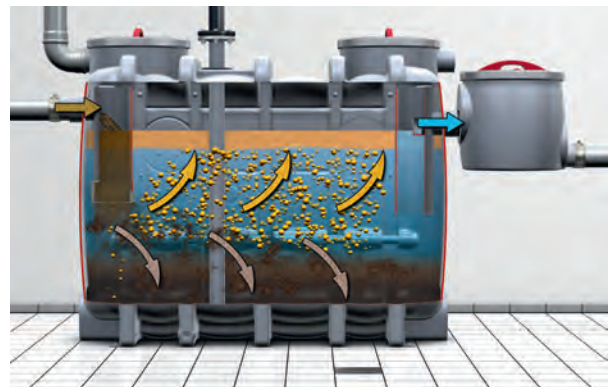

Operating principle for full disposal/below ground installation

With grease separators for full disposal and below ground installation, sludge and grease are also collected in the separator container and picked up by a disposal contractor at certain intervals or as required. The grease separator takes up less space of the outdoor surface and can be emptied in a way that minimises odours via direct suction equipment installed in the soil.

Video

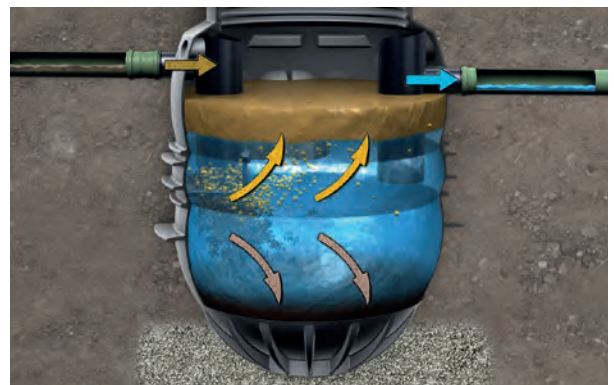

Operating principle for partial disposal

With grease separators for partial disposal, sludge and grease are collected in separate containers. This can be done manually or automatically via an additional control.

Video



Grease separators for partial disposal

Grease separators for partial disposal (Fresh grease separators)

Grease separators working on the partial disposal principle also operate purely physically on the basis of gravity (density differences), i.e. heavy waste water constituents sink to the floor of the separator, whilst light substances such as animal oils and fats rise to the top of the separator. The separated substances (grease and sludge) are collected in separate containers. The treated waste water is then discharged into the sewers via the drainage outlet pipe.



Draining the separated substances from the grease separator into the collecting drums is done by opening the relevant drainage valve on the separator (specifics depend on the type of operation). This can be undertaken independently of normal operations. For example, it can be done without interrupting the work being carried out in a kitchen. Because the collecting drums only take up grease and sludge, the grease separator does not have to be filled after disposal with expensive fresh water.



Partial disposal concept

ACO Building Services provides two types of grease separator for partial disposal: grease separators for manual, or automatic partial disposal. Both of these versions are only available for free-standing installation.

The grease separators for manual partial disposal (LIPATOR) have mechanical drainage valves. These must be opened several times a day as required by the operator (after heating up first). The transparent hoses reveal whether all of the substances collected at any given time have completely drained into the drums.

The grease separators with automatic partial disposal (LIPATOMAT) have electrically actuated ball valves. A programme control automatically activates the pre-heating and opens the valves. An optical and acoustic warning signal is activated when the collecting drums are full. Full drums are simply replaced and collected by a disposal company.



Lipator-S-RM:
Grease separator for partial disposal, for manual grease/sludge extraction



Lipator-S-RA:
Grease separator for partial disposal, for automated grease/sludge extraction

Grease separators for full disposal

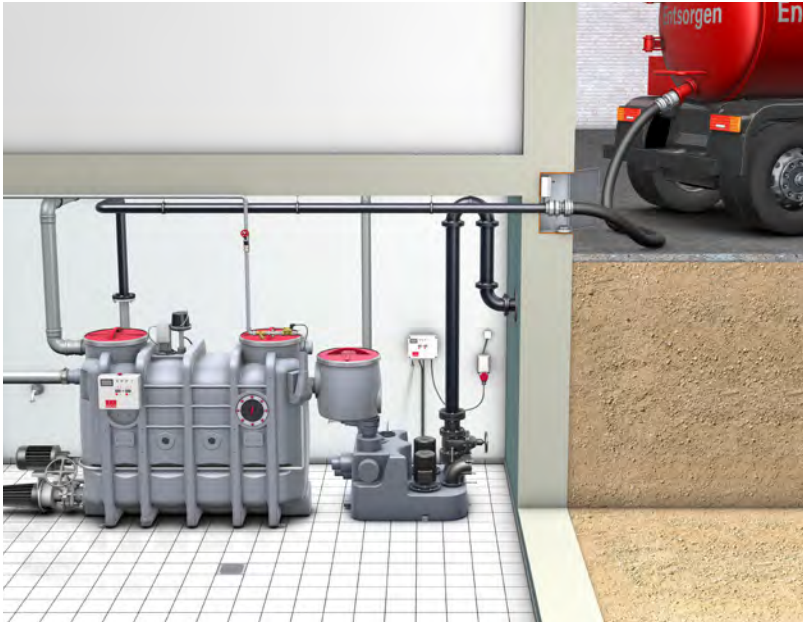

A grease separator for full disposal operates purely physically on the basis of gravity (density differences), i.e. heavy waste water constituents sink to the floor of the separator, light substances such as animal fats and oils, rise to the top of the grease separator. The treated waste water is discharged into the sewers via a drainage outlet pipe. The sludge trap and the separator must be completely emptied and cleaned at least once a month pursuant to EN 1825. Emptying the sludge trap and the separator is carried out by a disposal company and it is recommended that this operation be carried out every two weeks. The separator then has to be refilled with water (e.g. drinking water or process water) in compliance with the local water regulations.

For free-standing installation



For below ground installation



- Structural stability of the container with proof of stability for over 25 years
- Minimises disposal and maintenance costs thanks to economic step increases in nominal size
- Easy upgrade of simple separator variants with additional components for convenient operation and disposal
- Various shapes and materials

- Structural stability of the container with proof of stability for 50 years
- No need to cast the load distribution plate (ready to install)
- Available for load class A 15, B 125 or D 400
- For load class D 400, no need to concrete the container in, even with the highest possible ground water level

Materials and models



Polyethylene

- **Very durable**
Polyethylene has excellent corrosion-resistance properties
- **Recycling**
Polyethylene is environmentally-friendly and reusable
- **Maintenance**
Cleaning is simple thanks to the smooth wax-like surface
- **Transport**
Low weight for easy transport and installation



Stainless Steel

- **Fire protection**
Stainless steel is completely inflammable and therefore presents zero fire-risk. It is also very temperature-resistant
- **Strength**
Stainless steel has very high levels of mechanical strength and is therefore vandal-proof
- **Hygiene**
Stainless steel has been used for many decades in all applications specifying strict hygiene regulations (e.g. hospitals)
- **Chemical resistance**
Stainless steel is extremely resistant to organic substances



Oval Model

The container dimensions of the oval grease separators made of polyethylene and stainless steel have been optimised to maximise ease of access in awkward situations. This means they can be easily carried into areas via narrow stairs and door openings.

NS 1-4: max. width 800 mm
NS 5.5-10: max. width 1050 mm



Round Models

The round grease separator models made of stainless steel or polyethylene can be dismantled into separate components. This design also means that the nominal size can be enlarged on site by simply replacing the middle components (e.g. replacing NS 7 with NS 10).

Number of separate components:
NS 2-4: 2 components; Ø 1000 mm
NS 7-10: 3 components; Ø 1500 mm
NS 15-20: 3 components; Ø 1750 mm

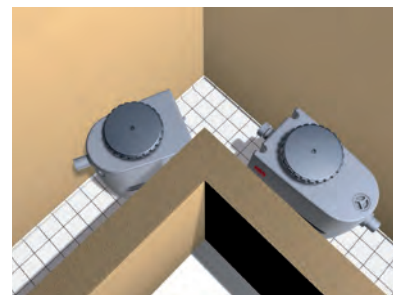

Split Design

This product line is made of polyethylene and is specially designed for remediation projects with very narrow access routes. The separator can be split into three parts. Maximum segment dimensions (LxWxH):

NS2: 670 x 700 x 1360 mm
NS4: 1140 x 700 x 1360 mm

Product benefits: ACO extension stage system

A grease separator must be emptied at regular intervals by a disposal vehicle. The extension stage system means that odour nuisance can be reduced during disposal and cleaning. The higher the extension stage, the easier to carry out the disposal and cleaning of the grease separator.

The available extension stages and the respective ease of disposal and cleaning they provide can be seen in the table below.

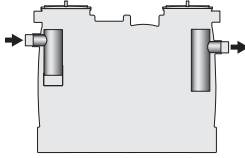
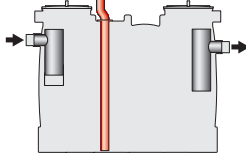
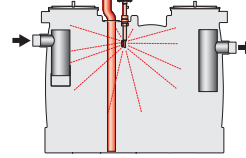
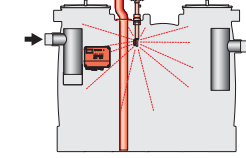
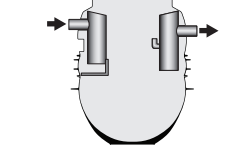
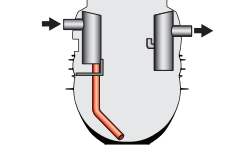
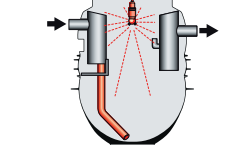
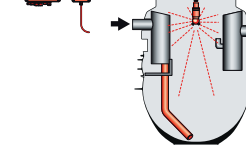
Basic model	Extension stage 1	Extension stage 2	Extension stage 3
For free-standing installation			
			
For below ground installation			
			
<ul style="list-style-type: none"> ■ Disposal via inspection covers 	<ul style="list-style-type: none"> ■ With connection for direct suction 	<ul style="list-style-type: none"> ■ With connection for direct suction ■ With internal high pressure cleaning (manual operation) ■ With filling device (manual) 	<ul style="list-style-type: none"> ■ With connection for direct suction ■ With internal high pressure cleaning (automated operation) ■ With filling device (automated)
Occurrence of odour during disposal and cleaning	Disposal can be done without opening of the covers. Occurrence of odour is likely during cleaning of the tank.	No odour during disposal and cleaning. Filling device, high pressure spray head and disposal pump are manually operated.	No odour during disposal and cleaning. Filling device, high pressure spray head and disposal pump are operated automatically.

Planning notes: pipework, ventilation (EN 1825-2)

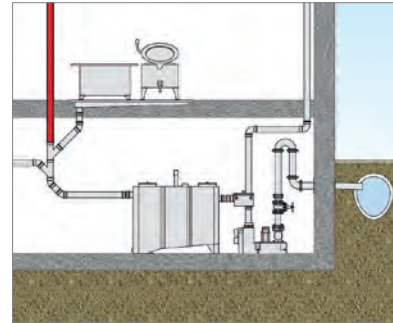
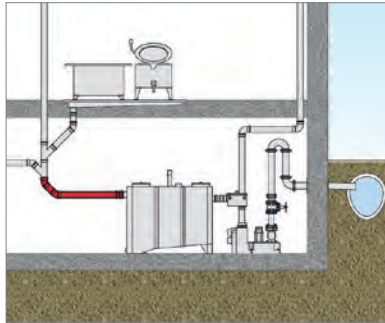
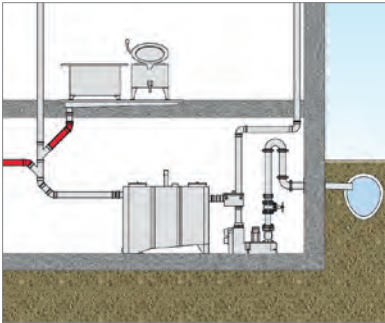

■ When installing the inlet line through unheated or freely accessible spaces where there is a danger of frost, this section of the route must be designed with auxiliary pipe heating (e.g. self-regulating strip heaters and insulation).

■ Inlet lines must be designed and installed carefully, as even this can have a positive or negative influence on separator efficiency.

■ Where vertical inlet lines meet the horizontal pipe, they must be designed as follows in order to prevent impermissible whirling of the waste water and its greasy contents:
vertical downpipe, 45° bend, straight pipe section, horizontal pipeline of at least 250 mm, at least 10 x ND long at the grease separator inlet (example: ND 100 = 1000 mm, ND 150 = 1500 mm).

■ The inlet and outlet lines on grease separator systems must be adequately ventilated. To this end, route the vent stack to above the roof (EN 1825-2).

■ Other horizontal connecting lines longer than 5 m must be ventilated in addition. If the horizontal inlet line is longer than 10 m and there are no other additionally ventilated connecting lines, the inlet line must be fitted with an extra vent stack right by the separator inlet (EN 1825-2).

Planning notes: pipework with ACO PIPE pipe systems

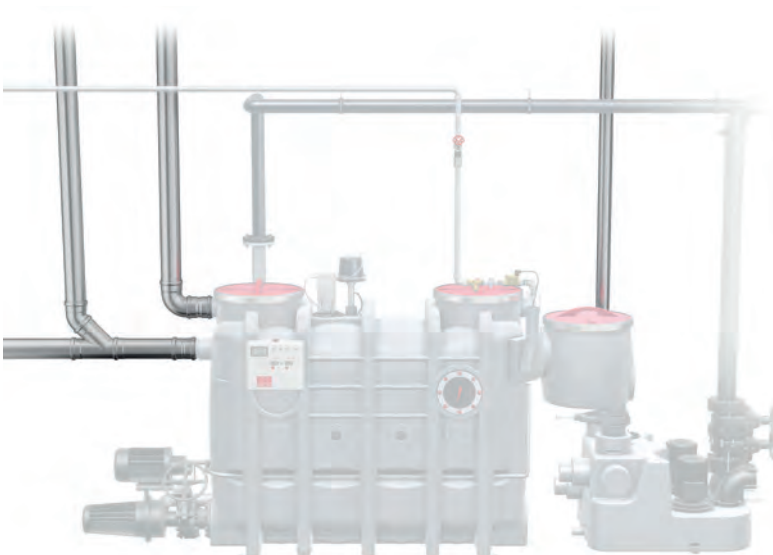

Materials that are resistant to corrosion and fatty acids must be used for the inlet and ventilation lines of grease separator plants in particular. Stainless steel, material grade 316 is recommended here.

With ACO PIPE, ACO Building Drainage provides a pipe system that is ideally suited for this purpose.

Planning notes: high-pressure inner cleaning of ACO grease separators



High-pressure inner cleaning of a grease separator for disposal leaving no residue

Unpleasant smells produced when disposing of the contents of grease separators are often equated with hygiene deficiencies. In order to prevent this, ACO grease separators are available with optional hydro-mechanic high-pressure inner cleaning. This enables the inside walls of the grease separator to be intensively cleaned, without having to open the covers. The spread of smells throughout the premises where the grease separator is installed is therefore minimised during the cleaning process. A rotating cleaning head, which rotates not only horizontally, but also vertically, is used here.

The cleaning head performs two tasks:

- Breaks up the grease layer and homogenises it to facilitate suction emptying
- Cleans the inside walls of the container

Only a cold water connection is required for the associated high-pressure pump. The cleaning unit can be designed for either manual or fully automatic control. Cleaning progress can be checked through the inspection window provided.

Planning notes: upstream tank plants with eccentric screw pumps



Application: inlet connection upstream of grease separator plants too low

Low inlet heights always lead to problems if there is no gradient between the inlet line and the grease separator. If structural conditions mean the grease separator cannot be placed any lower in such cases, then the waste water must be

pumped to it. However, due to the grease content of the waste water, this cannot be done using a traditional lifting plant. This would furthermore cause whirling to occur in the separator, which would impair the separation process.

Planning notes: drainage below the backflow level

If the grease separator is installed below the backflow level, drainage must be ensured by a twin lifting plant. Where grease separators installed in a basement are concerned, the top of the road surface (edge of curbstone) usually forms the backflow level. As such, practically every grease separator must be drained via a twin lifting plant. This requirement must be strictly observed, particularly for free-standing separators in buildings, even if there is only an occasional risk of backflow. The grease separator is only suitable and approved for operation without pressure. Odour-proof is not the same as backflow-proof! A twin lifting plant must be installed (requirement in industrial and commercial fields) in order to ensure uninterrupted

operation should one pump fail. Furthermore, it should be noted that greasy contents can become separated from waste water again downstream of every grease separator, leading to deposits in the lifting plant container. It is therefore necessary to regularly inspect the lifting plant in conjunction with servicing the grease separator. These grease deposits also have a negative impact on filling level measuring components such as float switches, ball joint switches and pilot tubes whose cross sections are not large enough. Filling level measuring equipment should be installed that has a generously dimensioned pilot tube cross section with air bubble injection for self-cleaning purposes.

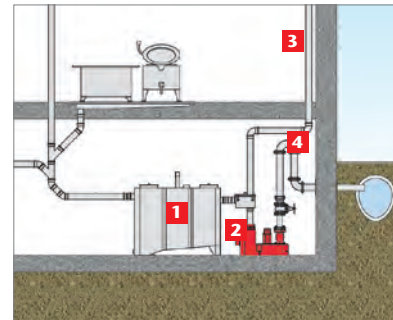

- 1 Grease separator plant
- 2 Lifting plant
- 3 Ventilation line (separately over roof)
- 4 Backflow loop

Application: grease separator below backflow level with downstream lifting plant



Waste water lifting plants convey waste water above the backflow level into the higher sewage system. EN 12056 stipulates that waste water lifting plants must be used where drainage points are below the backflow level, i.e. for almost all free-standing grease separator plants. Depending on the application scope, ACO offers a choice of different waste water lifting plants that can be installed directly behind the grease separators.

Planning notes: increased operational safety thanks to air bubble injection

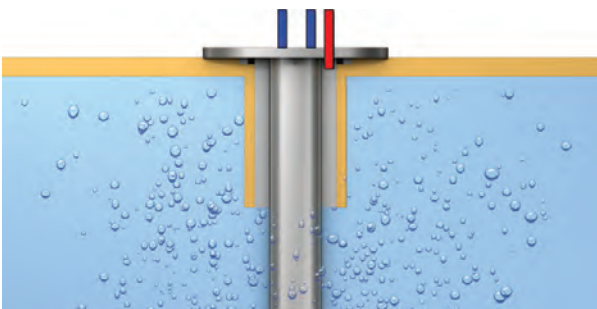

Air is blown into the pilot tube continuously via a compressor. The air bubbles which rise at the end of the pilot tube create a constant motion beneath it, so no media that generate floating surfaces (e.g. residual grease from the separator) are able to set. This guarantees that level measuring equipment works very reliably.

ACO pumping stations



If construction conditions are very confined, in some cases it may be necessary to install a pumping station outside the building, instead of a lifting plant inside it. The size of the pumping station to be chosen will depend on the upstream separator and any other volume flows to be introduced. ACO pumping station containers are made of polyethylene and characterised, amongst other things, by good stability, high resistance and maximum protection against upwelling. ACO pumping stations have been designed based on a modular principle: the customer is able to select the load class, the control, the type of level measuring, the pump and any miscellaneous accessories.

GSM module for checking operating conditions

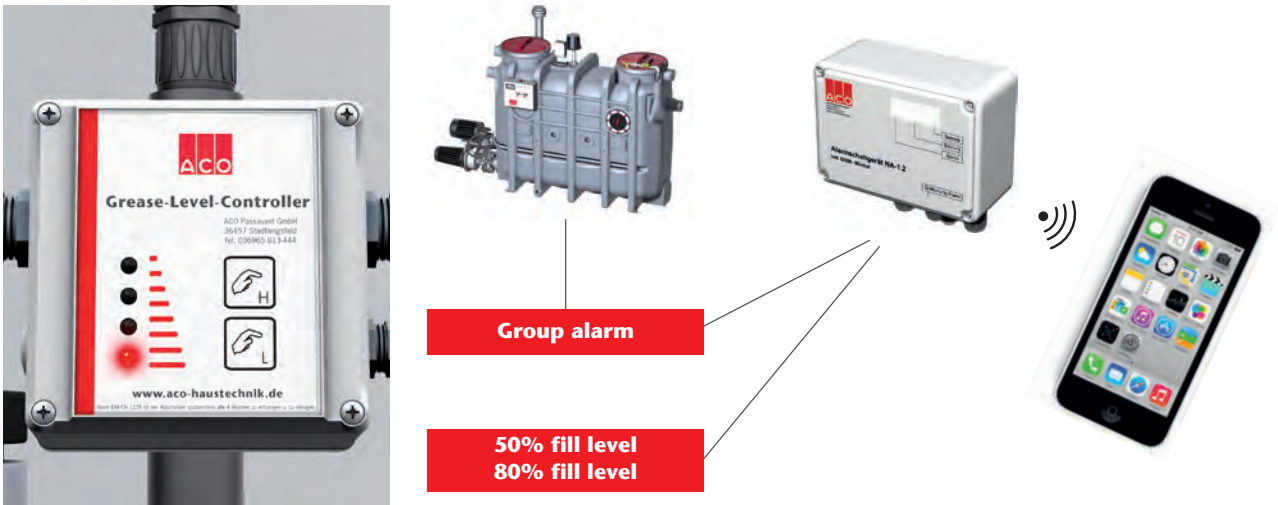

The sensor head of the measuring equipment for grease layer thickness uses electrodes arranged in various ways to detect the difference in the conductivity of water, grease and air. This enables the boundary layers between the water phase and the grease layer that is floating up, and between the grease layer and the surrounding air to be determined. Maximum fill levels are then indicated on the fill level monitoring lamp display. The operator has a high degree of flexibility in terms of device maintenance thanks to a GSM module that makes the process of checking and servicing grease separators, waste water lifting plants, backflow stops and process engineering plants much easier, more adaptable and faster.

It is particularly well suited to grease separator plants and their stringent drainage requirements and is available as a constituent part or as a component for retrofitting. Grease separators with a traditional design are equipped with inspection windows so the grease layer thickness can be measured visually, whereas on modern devices, this measurement is taken automatically by measuring equipment for grease layer thickness. The GSM module enables the operating parameters to be retrieved via mobile phone and takes care of data transfer and the notification of disposal cycles and malfunctions – all fully automatically.

ACO odour neutraliser



The ACO odour neutraliser significantly reduces the formation of noxious smells in all vent stacks and plant components.

The composition of the waste water means that unpleasant smells are created in the grease separator both when the kitchen is operational and during idle periods. If vent stacks have been installed incorrectly, this can lead to a perceptible odour nuisance at critical line components and drainage points. But help is at hand in the form of the ACO odour neutraliser: a flexible interval timer controls the dosing of an odour neutralising agent, preferably into the ventilation line, which overrides the unpleasant smells in the plant components. Irrespective of any problems with line components, this makes really good sense primarily for low extension stages which require a lot of cleaning, as it can significantly reduce the spread of odours through the premises during monthly disposal of the separator contents.

Waste water treatment that goes further

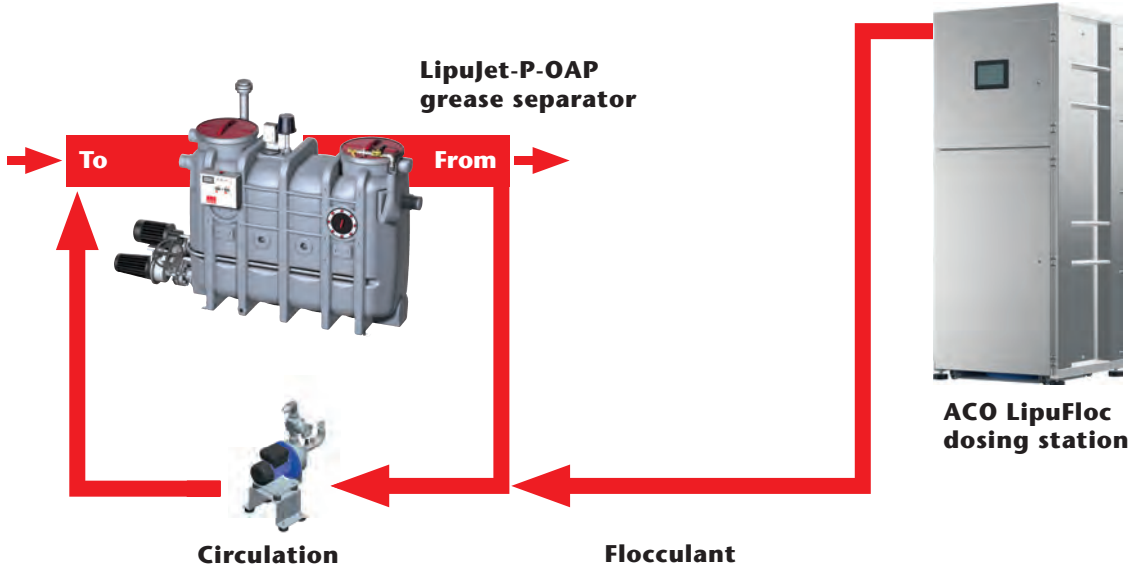

System technology for clean waste water

The ACO LipuFloc dosing station consists of two physically separate components. On the one hand, a stainless steel housing for the dosing mechanism and the supply of the chemical substance, on the other hand, a circulation unit. The stainless steel housing contains the dosing pump with a suction nozzle, controls and fusebox, level and quantity monitoring of the supply of the chemical substance, as well as an operation and control centre (colour touch screen) in the front door. The built-in dosing pump transfers the chemical substance

towards the grease separator for use, based on time and volume parameters. This is extracted from the plastic barrel directly using a suction nozzle with level measurement. The chemical substance is held in a barrel which stands on a dolly and is pushed into the housing, making it easy to replace. The level and quantity in the container is monitored continuously. The control is the central component where all the information about fill levels and operating conditions comes together.

The first element described above provides the power and controls to operate the second element. This is primarily a waste water pump which takes the pre-treated kitchen waste water from the grease separator's gully and, after the chemical substance has been added, pumps it back into the grease separator's inlet. These parts are normally fitted directly adjacent to the grease separator itself.



Product overview of ACO grease separators

Full disposal

Below ground installation **Page 28**

The waste water contents of grease separators for below ground installation must be disposed of at regular intervals. They can be used with corresponding manhole covers for load classes A, B and D according to EN 124. Just like the grease separators for free-standing installation and full disposal, the alternatives for below ground installation are also available in various extension stages.

Free-standing installation **Page 37**

The entire waste water contents of grease separators for full disposal must be disposed of at regular intervals in accordance with legal standards. Then the containers must be cleaned, depending on requirements. The higher the extension stage of the grease separator, the easier it is to dispose of the waste water contents, clean the container and re-fill the separator, and the less odour will be produced.

Mobile solution **Page 60**

The waste water containing grease produced by mobile snack bars and the like can be treated using mobile grease separators. In such cases, the accumulated grease must be disposed of daily.

Partial disposal **Page 62**

Grease separators for partial disposal give the operator the option to collect grease and sludge in separate drums. These separators are mainly used where structural or logistical restrictions mean it is not possible to use disposal vehicles to empty the contents of the grease separator. Full drums must be constantly replaced with empty containers in order to guarantee operational safety.

Product overview

ACO Passavant LipuMax-P grease separator made of polyethylene for below ground installation



ACO product benefits

- Compact construction – polyethylene
- Buoyancy-proof shaft to top edge of manhole cover with no in-situ concreting required (for D 400)
- Structural stability of the container with proof of stability for 50 years
- Load class up to D 400

Product information

- Grease separator plant according to EN 1825
- With integrated sludge trap
- For below ground installation, for top sections with load class A15, B125 or D400 according to EN 124
- Inlets and outlets for connections to plastic pipes

Table of dimensions

NS	ND	Contents [l]			Dimensions [mm]				
		Sludge trap	Grease storage volume	Total	D	H	H1	H2	H3
2	100	245	270	720	110	1377	1015	945	1147
	100	460	270	930	110	1594	1235	1165	1364
4	100	460	270	930	110	1594	1235	1165	1364
	100	980	270	1465	110	2129	1745	1675	1899
5.5	150	570	230	1465	160	2129	1745	1675	1899
	150	1065	230	1960	160	2611	2226	2156	2381
7	150	730	285	1675	160	2346	1960	1890	2116
8.5	150	860	360	1900	160	2558	2172	2102	2328
10	150	1010	415	2170	160	2828	2443	2373	2598

www.aco-haustechnik.de/katalog/Artikel-Nr.

All digital contents (data sheets (PDF)), dimensional drawings (DXF, IGS) and article descriptions (Datanorm, GAEB, TXT) relating to the grease separators and additional components represented here can be retrieved from the website stated above using the respective article number.

Dimensional drawings

LipuMax-P-B (Basic model)

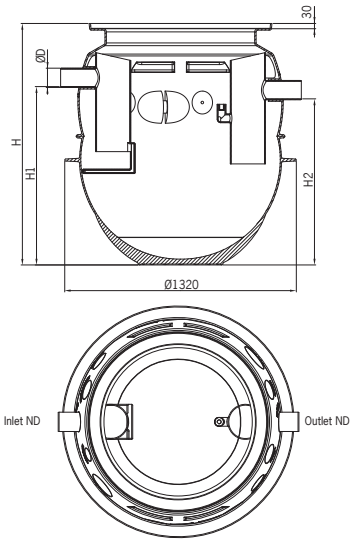

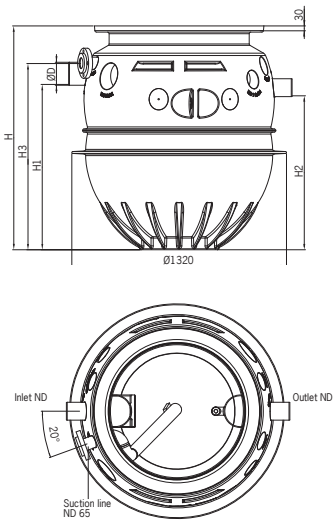

LipuMax-P-D (Extension stage 1)



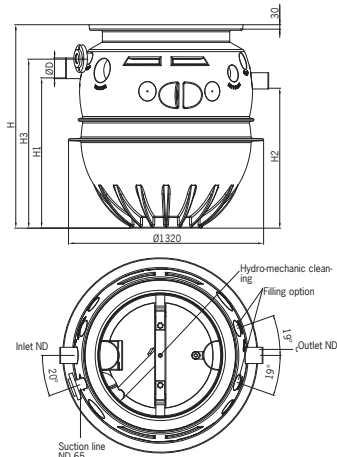
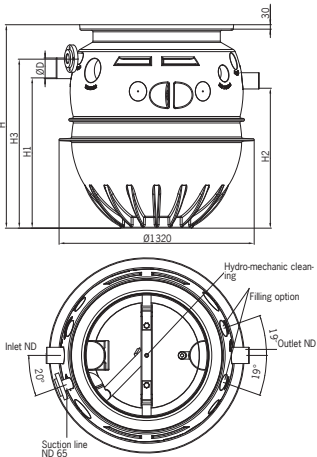

LipuMax-P-DM (Extension stage 2) LipuMax-P-DA (Extension stage 3)



Article No.

		
NS	LipuMax-P-B Basic model	LipuMax-P-D Extension stage 1
2	3202.80.00	3202.81.00
2	3202.80.10	3202.81.10
4	3204.80.00	3204.81.00
4	3204.80.10	3204.81.10
5.5	3205.80.00	3205.81.00
5.5	3205.80.10	3205.81.10
7	3207.80.00	3207.81.00
8.5	3208.80.00	3208.81.00
10	3210.80.00	3210.81.00

		
NS	LipuMax-P-DM Extension stage 2	LipuMax-P-DA Extension stage 3
2	3202.82.00	3202.83.00
2	3202.82.10	3202.83.10
4	3204.82.00	3204.83.00
4	3204.82.10	3204.83.10
5.5	3205.82.00	3205.83.00
5.5	3205.82.10	3205.83.10
7	3207.82.00	3207.83.00
8.5	3208.82.00	3208.83.00
10	3210.82.00	3210.83.00

Product overview

Top sections, load class A 15 – information for ordering

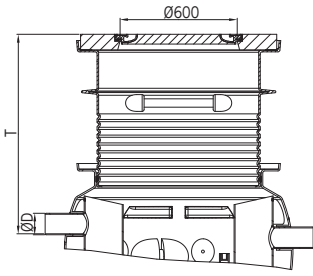

- Load class A 15 according to EN 124
- Concrete frame with cast iron cover
- Clear width \varnothing 600 mm
- Manhole cover odour-proof when closed
- Polyethylene top section (only included with article numbers 3300.14.01 and 3300.14.02)

	NS 2 SF 200	NS 2 SF 400	NS 4 SF 400	NS 4 SF 800	NS 5.5 SF 550	NS 5.5 SF 1100	NS 7 SF 700	NS 8.5 SF 850	NS 10 SF 1000	Weight [kg]	Article no.
T [mm]	420	420	420	420	445	445	445	445	445	145	3300.14.00
	720-1020	720-1020	720-1020	720-1020	745-1045	745-1045	745-1045	745-1045	745-1045	170	3300.14.01
	720-1985	720-1985	720-1985	720-1830	745-1855	745-1370	745-1640	745-1430	745-1160	193	3300.14.02

Top sections, load class B 125 – information for ordering

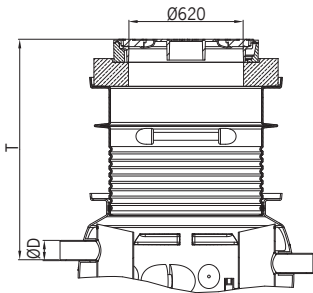

- Load class B 125 according to EN 124
- SAKU cover with concrete frame
- Clear width \varnothing 600 mm
- Manhole cover odour-proof when closed
- Concrete adapter plate \varnothing 1000 mm x 150 mm
- Polyethylene top section (only included with article numbers 3300.15.01 and 3300.15.02)

	NS 2 SF 200	NS 2 SF 400	NS 4 SF 400	NS 4 SF 800	NS 5.5 SF 550	NS 5.5 SF 1100	NS 7 SF 700	NS 8.5 SF 850	NS 10 SF 1000	Weight [kg]	Article no.
T [mm]	585	585	585	585	610	610	610	610	610	282	3300.15.00
	885-1195	885-1195	885-1195	885-1195	910-1220	910-1220	910-1220	910-1220	910-1220	307	3300.15.01
	885-1985	885-1985	885-1985	885-1830	910-1855	910-1370	910-1640	910-1430	910-1160	330	3300.15.02

Top sections, load class D 400 – information for ordering

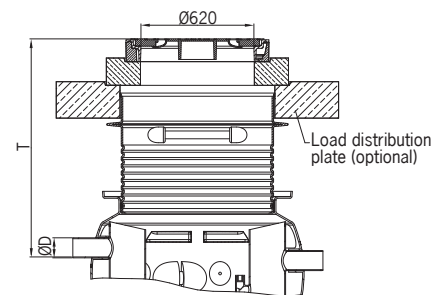

- Load class D 400 according to EN 124
- Concrete frame with cast iron cover
- Clear width \varnothing 600 mm
- Manhole cover odour-proof when closed
- Concrete adapter plate \varnothing 1000 mm x 150 mm
- Polyethylene top section
- Optionally with concrete load distribution plate \varnothing 1500 mm x 200 mm

	NS 2 SF 200	NS 2 SF 400	NS 4 SF 400	NS 4 SF 800	NS 5.5 SF 550	NS 5.5 SF 1100	NS 7 SF 700	NS 8.5 SF 850	NS 10 SF 1000	Weight [kg]	Article no.
T [mm] without load distribution plate	865-1985	865-1985	865-1985	865-1830	890-1855	890-1370	890-1640	890-1430	890-1160	330	3300.17.00
T [mm] with load distribution plate	865-1985	865-1985	865-1985	865-1830	890-1855	890-1370	890-1640	890-1430	890-1160	1030	3300.16.00

Top section type Nordic, load class A 15 – Order data

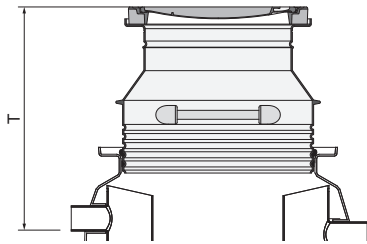

- load class A 15 according to EN 124
- frame from concrete, cover from cast iron
- clear opening Ø 600 mm
- cover odour proof sealed
- raising tube from polyethylene

*installation height can also be realized with item 3300.34.02

	NS 2 ST 200	NS 2 ST 400	NS 4 ST 400	NS 4 ST 800	NS 5.5 ST 550	NS 5.5 ST 1100	NS 7 ST 700	NS 8.5 ST 850	NS 10 ST 1000	Weight [kg]	Article No. [grey]
T [mm]	850-960	850-960	850-960	870-980	870-980	870-980	870-980	870-980	870-980	96	3300.34.11
	850-1410	850-1410	850-1410	870-1430	870-1430	870-1370	870-1430	870-1430	870-1150	104	3300.34.12
	850-1980	840-1760	840-1760	870-1850	870-1850	870-1370*	870-1640	870-1430*	870-1150*	115	3300.34.13

Top section type Nordic, load class B 125 – Order data

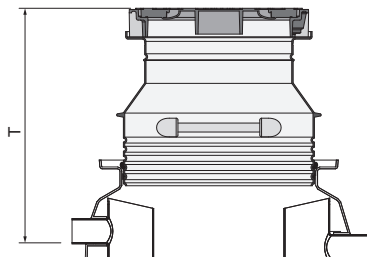

- load class B 125 according to EN 124
- frame from concrete, SAKU cover from polyethylene
- clear opening Ø 600 mm
- cover odour proof sealed
- raising tube from polyethylene

*installation height can also be realized with item 3300.35.02

	NS 2 ST 200	NS 2 ST 400	NS 4 ST 400	NS 4 ST 800	NS 5.5 ST 550	NS 5.5 ST 1100	NS 7 ST 700	NS 8.5 ST 850	NS 10 ST 1000	Weight [kg]	Article No. [grey]
T [mm]	900-1010	900-1010	900-1010	920-1040	920-1040	920-1040	920-1040	920-1040	920-1040	74	3300.35.11
	900-1460	900-1460	900-1460	920-1490	920-1490	920-1370	920-1490	920-1420	920-1150	82	3300.35.12
	900-1980	890-1760	890-1760	920-1850	920-1850	920-1370*	920-1640	920-1420*	920-1150*	93	3300.35.13

Top section type Nordic, load class D 400 – Order data

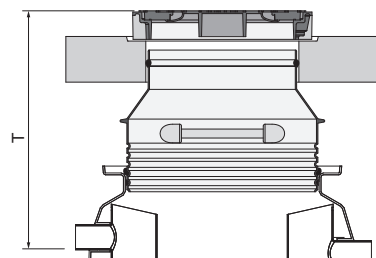

- load class D 400 according to EN 124
- frame from concrete, cover from cast iron
- clear opening Ø 600 mm
- cover odour proof sealed
- adapter plate from concrete Ø 1000 mm x 150 mm
- raising tube from polyethylene
- selectively with load distribution plate from concrete Ø 1500 mm x 200 mm

Load distribution plate	Raising tube length	NS 2 ST 200	NS 2 ST 400	NS 4 ST 400	NS 4 ST 800	NS 5.5 ST 550	NS 5.5 ST 1100	NS 7 ST 700	NS 8.5 ST 850	NS 10 ST 1000	Weight [kg]	Article No. [grey]
With	short	890-1010	890-1010	890-1010	920-1040	920-1040	920-1040	920-1040	920-1040	920-1040	846	3300.36.08
With	medium	890-1460	890-1460	890-1460	920-1490	920-1490	920-1490	920-1490	920-1420	920-1150	854	3300.36.09
With	long	890-1980	890-1760	890-1760	920-1850	920-1850	920-1370	920-1640	920-1420	920-1150	866	3300.36.10
Without	short	890-1010	890-1010	890-1010	920-1040	920-1040	920-1040	920-1040	920-1040	920-1040	85	3300.37.08
Without	medium	890-1460	890-1460	890-1460	920-1490	920-1490	920-1490	920-1490	920-1420	920-1150	93	3300.37.09
Without	long	890-1980	890-1760	890-1760	920-1850	920-1850	920-1370	920-1640	920-1420	920-1150	105	3300.37.10



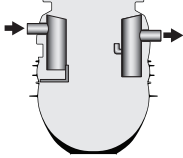
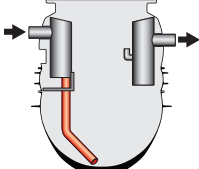
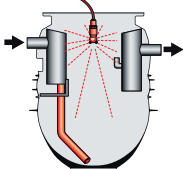
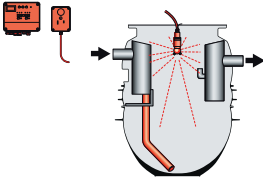

Product overview

Extension stage system LipuMax-P

Model	Disposal		Description
	No odour nuisance	Convenience	
LipuMax-P-B (basic model) 	—	—	<ul style="list-style-type: none"> ■ Disposal and cleaning by opening the cover (associated with the formation of noxious smells)
LipuMax-P-D (extension stage 1) 	✓	—	<ul style="list-style-type: none"> ■ Odour-free disposal via a connector to direct suction ■ After-cleaning by opening the cover (associated with the slight formation of noxious smells) ■ Disposal connection ND 65, counter flange with fire hose quick coupling 75B and 2½" blank cap
LipuMax-P-DM (extension stage 2) 	✓	manual	<ul style="list-style-type: none"> ■ Manual, odour-free disposal/cleaning via direct suction and hydro-mechanic high-pressure inner cleaning ■ Disposal connection ND 65, counter flange with fire hose quick coupling 75B and 2½" blank cap ■ Filling device with ball valve for re-filling with fresh water ■ Hydro-mechanic inner cleaning via high-pressure pump and spray head
LipuMax-P-DA (extension stage 3) 	✓	automatic	<ul style="list-style-type: none"> ■ Programmed, odour-free disposal/cleaning via direct suction and hydro-mechanic high-pressure inner cleaning (175 bar) ■ Disposal connection ND 65, counter flange with fire hose quick coupling 75B and 2½" blank cap ■ Filling device with solenoid valve for re-filling with fresh water ■ Hydro-mechanic inner cleaning via high-pressure pump and spray head

Supplementary components: Page 33 ff.



Optional system components

	Designation	To fit	Description	Article no.
	Sampling shaft body 800 ND 100	<ul style="list-style-type: none"> ■ LipuMax-P grease separators ■ Inlet inverts*: □ 800 mm: 3300.14.00 □ 1150 – 1380 mm: 3300.14.01 □ 1150 – 2380 mm: 3300.14.02 □ 970 mm: 3300.15.00 □ 1300 – 1550 mm: 3300.15.01 □ 1300 – 2550 mm: 3300.15.02 □ 1300 – 2540 mm: 3300.16.00 □ 1300 – 2540 mm: 3300.17.00 	<ul style="list-style-type: none"> ■ Made from plastic, material polyethylene ■ Gradient: 33 mm ■ Diameter: 846 mm ■ Weight: 38 kg 	3300.13.50
	Sampling shaft body 800 ND 100	<ul style="list-style-type: none"> ■ LipuMax-P grease separators ■ Inlet inverts*: □ 680 mm: 3300.14.00 □ 1020 – 1260 mm: 3300.14.01 □ 1020 – 2260 mm: 3300.14.02 □ 840 mm: 3300.15.00 □ 1190 – 1400 mm: 3300.15.01 □ 1190 – 2400 mm: 3300.15.02 □ 1170 – 2400 mm: 3300.16.00 □ 1170 – 2400 mm: 3300.17.00 	<ul style="list-style-type: none"> ■ Made from plastic, material polyethylene ■ Gradient: 160 mm ■ Diameter: 846 mm ■ Weight: 36 kg 	3300.13.51
	Sampling shaft body 800 ND 150	<ul style="list-style-type: none"> ■ LipuMax-P grease separators ■ Inlet inverts*: □ 860 mm: 3300.14.00 □ 1200 – 1440 mm: 3300.14.01 □ 1200 – 2400 mm: 3300.14.02 □ 1000 mm: 3300.15.00 □ 1360 – 1600 mm: 3300.15.01 □ 1360 – 2600 mm: 3300.15.02 □ 1350 – 2590 mm: 3300.16.00 □ 1350 – 2590 mm: 3300.17.00 	<ul style="list-style-type: none"> ■ Made from plastic, material polyethylene ■ Gradient: 33 mm ■ Diameter: 846 mm ■ Weight: 36 kg 	3300.13.52
	Sampling shaft body 800 ND 150	<ul style="list-style-type: none"> ■ LipuMax-P grease separators ■ Inlet inverts*: □ 730 mm: 3300.14.00 □ 1070 – 1300 mm: 3300.14.01 □ 1070 – 2300 mm: 3300.14.02 □ 890 mm: 3300.15.00 □ 1240 – 1480 mm: 3300.15.01 □ 1240 – 2480 mm: 3300.15.02 □ 1220 – 2460 mm: 3300.16.00 □ 1220 – 2460 mm: 3300.17.00 	<ul style="list-style-type: none"> ■ Made from plastic, material polyethylene ■ Gradient: 160 mm ■ Diameter: 846 mm ■ Weight: 39 kg 	3300.13.53

*ACO top sections (Page 34)



Supplementary components

Optional system components

	Designation	To fit	Description	Article no.	
	Sampling shaft 450 ND 100	<ul style="list-style-type: none"> ■ LipuMax-P grease separators for below ground installation □ NS 2 – 4 	<ul style="list-style-type: none"> ■ Made from plastic, material polyethylene ■ With concrete-cast iron cover □ Clear width: 450 mm □ Load class: B 125 or D 400 (with in-situ load distribution plate) ■ Odour-proof ■ Weight: 128 kg ■ Inlet invert T □ 440 – 1120 mm for B 125 □ 540 – 1420 mm for D 400 	<p style="text-align: right;">Gradient: 153 mm H = 258 mm</p> <p style="text-align: right;">Gradient: 33 mm H = 138 mm</p>	<p style="text-align: right;">3300.13.10</p> <p style="text-align: right;">3300.13.11</p>
	Sampling shaft 450 ND 150	<ul style="list-style-type: none"> ■ LipuMax-P grease separators for below ground installation □ NS 5.5 – 10 	<ul style="list-style-type: none"> ■ Made from plastic, material polyethylene ■ With concrete-cast iron cover □ Clear width: 450 mm □ Load class: B 125 or D 400 (with in-situ load distribution plate) ■ Odour-proof ■ Weight: 128 kg ■ Inlet invert T □ 440 – 1120 mm for B 125 □ 540 – 1420 mm for D 400 	<p style="text-align: right;">Gradient: 159 mm H = 239 mm</p> <p style="text-align: right;">Gradient: 75 mm H = 155 mm</p>	<p style="text-align: right;">3300.13.20</p> <p style="text-align: right;">3300.13.21</p>
	Sampling shaft 450 ND 100 with load distribution plate	<ul style="list-style-type: none"> ■ LipuMax-P grease separators for below ground installation □ NS 2 – 4 	<ul style="list-style-type: none"> ■ Buoyancy-proof up to upper edge of site ■ Made from plastic, material polyethylene ■ With concrete-cast iron cover □ Clear width: 450 mm □ Load class: D 400 ■ Odour-proof ■ Weight: 545 kg ■ Inlet invert: 540 – 1420 mm 	<p style="text-align: right;">Gradient: 153 mm H = 258 mm</p> <p style="text-align: right;">Gradient: 33 mm H = 138 mm</p>	<p style="text-align: right;">3300.13.15</p> <p style="text-align: right;">3300.13.16</p>

	Designation	To fit	Description	Article no.
	Sampling shaft 450 ND 150 with load distribution plate	<ul style="list-style-type: none"> ■ LipuMax-P grease separators for below ground installation □ NS 5.5 – 10 	<ul style="list-style-type: none"> ■ Buoyancy-proof up to upper edge of site ■ Made from plastic, material polyethylene ■ With concrete-cast iron cover <ul style="list-style-type: none"> □ Clear width: 450 mm □ Load class: B 125 or D 400 (with in-situ load distribution plate) ■ Odour-proof ■ Weight: 546 kg ■ Inlet invert: 540 – 1420 mm <p style="text-align: right;">Gradient: 159 mm H = 239 mm</p> <p style="text-align: right;">Gradient: 75 mm H = 155 mm</p>	<p style="text-align: right;">3300.13.25</p> <p style="text-align: right;">3300.13.26</p>
	Extension 450	<ul style="list-style-type: none"> ■ Sampling shafts 	<ul style="list-style-type: none"> ■ Made from plastic, material polyethylene ■ For fitting on upstream sampling shaft for deep installations ■ Extension height: 100 – 650 mm (can be reduced by 45 mm each time by separating at cutting marks) ■ Maximum of two extensions possible per shaft system ■ Weight: 12 kg 	<p style="text-align: right;">3300.13.00</p>
	Disposal shaft 450	<ul style="list-style-type: none"> ■ Grease separators for below ground installation □ LipuMax-P-D □ LipuMax-P-DM □ LipuMax-P-DA 	<ul style="list-style-type: none"> ■ Made from plastic, material polyethylene ■ With concrete-cast iron cover <ul style="list-style-type: none"> □ Clear width: 450 mm □ Load class: B 125 or D 400 (with in-situ load distribution plate) ■ Weight: 120 kg ■ Installation height: 1500 mm 	<p style="text-align: right;">3300.30.00</p>
	Disposal shaft 450 with load distribu- tion plate	<ul style="list-style-type: none"> ■ Grease separators for below ground installation □ LipuMax-P-D □ LipuMax-P-DM □ LipuMax-P-DA 	<ul style="list-style-type: none"> ■ Buoyancy-proof up to upper edge of site ■ Made from plastic, material polyethylene ■ With concrete-cast iron cover <ul style="list-style-type: none"> □ Clear width: 450 mm □ Load class: D 400 ■ Weight: 520 kg 	<p style="text-align: right;">3300.30.01</p>
	Extension	<ul style="list-style-type: none"> ■ Disposal shafts 	<ul style="list-style-type: none"> ■ Made from plastic, material polyethylene ■ For fitting on upstream ■ Sampling shaft for deep installations ■ Extension height: 100 – 650 mm (can be reduced by 45 mm each time by separating at cutting marks) ■ Weight: 12 kg 	<p style="text-align: right;">3300.31.00</p>

Supplementary components

	Designation	To fit	Description	Article no.
	Measuring device for grease layer thickness	<ul style="list-style-type: none"> ■ LipuMax-P grease separators for below ground installation 	<ul style="list-style-type: none"> ■ For electronic measurement of grease layer ■ Suitable for liquid and/or congealing grease ■ Measuring device with connecting cable ready to plug in, length: 3 m ■ With two isolated change-over contacts to display full warning (100%) and advance warning of fill level (80%) ■ With visual display of fill level for advance warning and full warning ■ With heated probe rod to increase operating reliability ■ Operating voltage: 230 V/50 Hz ■ Max. consumption approx. 12 W 	
			Cable length: 10 metres	3300.11.70
			Cable length: 20 metres	3300.11.71
			Cable length: 30 metres	3300.11.72
	Signalling unit with GSM module	<ul style="list-style-type: none"> ■ Grease separators extension stage 3 ■ Measuring equipment for grease layer thickness 	<ul style="list-style-type: none"> ■ Mains-independent ■ Visible and audible alarm signals ■ 6 digital & 2 analogue freely configurable inputs ■ 1 alarm output 12 V ■ Includes GSM antenna (2.5 m cable) ■ Relaying alarms to mobile phones by SMS ■ For mounting outside the ex area ■ Housing: 155 x 180 x 103 mm ■ Slot for standard SIM card ■ Protection type: IP 54 (with mounted antenna plug IP 44) ■ Operating voltage: 230 V/AC 50/60 Hz 	0150.46.94
	Supporting ring	<ul style="list-style-type: none"> ■ LipuMax-P grease separators for below ground installation □ Load class: B125/D400 	<ul style="list-style-type: none"> ■ Made from concrete ■ Diameter: 625 mm ■ Without sealing ■ Displacement-proof 	
			Heights: 60 mm excluding mortar joints 70 mm including mortar joints Weight: 50 kg	8700.20.00
			Heights: 80 mm excluding mortar joints 90 mm including mortar joints Weight: 60 kg	8700.20.10
			Heights: 100 mm excluding mortar joints 110 mm including mortar joints Weight: 70 kg	8700.20.20

Lipujet-P – oval grease separators made of polyethylene for free-standing installation



ACO Product advantages

- Rugged construction with 25-year stability verification
- Disposal and maintenance cost minimisation thanks to staggered nominal sizes (e.g. NS 5.5 and 8.5)
- Extension stages 2 and 3 with multifunctional filling unit for high pressure internal cleaning and container filling

Product information

- Grease separator plant according to EN 1825
- With integrated sludge trap
- For free-standing installation in frost-proof premises
- Inlets and outlets for connections to plastic pipes

Table of dimensions

NS	ND	content [l]			Dimensions [mm]									Extension Dimensions [mm]				
		Sludge trap	Grease storage volume	Total	H1	H2	H3	H4	L1	L2	B1	B2	D	H5	L3	B3	L4	B4
1	100	106	100	320	830	760	1480	1300	1100	1300	700	770	110	1500	1400	800	1800	930
2	100	210	100	440	1055	985	1680	1500	1100	1300	700	770	110	1700	1400	800	1800	930
3	100	300	150	630	1055	985	1680	1500	1450	1650	700	770	110	1700	1750	800	2150	930
4	100	400	200	830	1055	985	1680	1500	1760	2000	700	770	110	1700	2060	800	2460	930
5.5	150	725	360	1430	1250	1180	1880	1700	1760	2000	950	1020	160	1900	2060	1050	2460	1180
7	150	800	400	1600	1250	1180	1880	1700	1960	2200	950	1020	160	1900	2260	1050	2660	1180
8.5	150	940	475	1900	1250	1180	1880	1700	2250	2485	950	1020	160	1900	2550	1050	2950	1180
10	150	1000	520	2000	1250	1180	1880	1700	2450	2690	950	1020	160	1900	2750	1050	3150	1180

www.aco-haustechnik.de/catalogue/Article no.

All digital contents (data sheets (PDF)), dimensional drawings (DXF, IGS) and article descriptions (Datanorm, GAEB, TXT) relating to the grease separators and additional components represented here can be retrieved from the website stated above using the respective article number.

Product overview

Dimensional drawings

LipuJet-P-OB (Basic model)

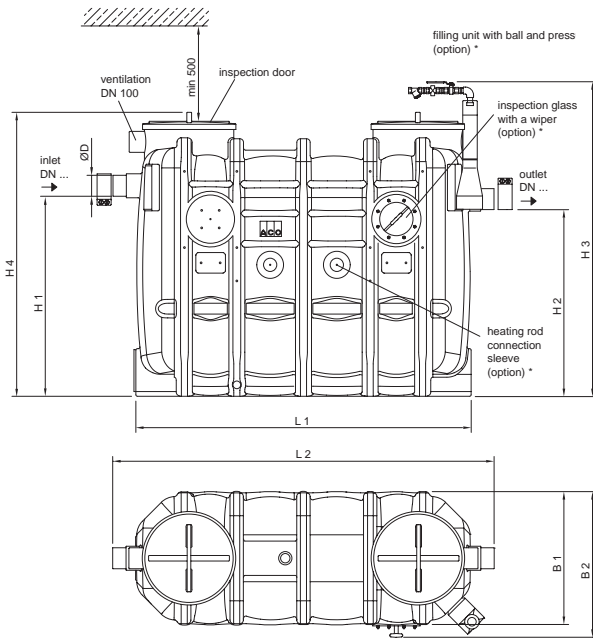

LipuJet-P-OM (Extension stage 2)

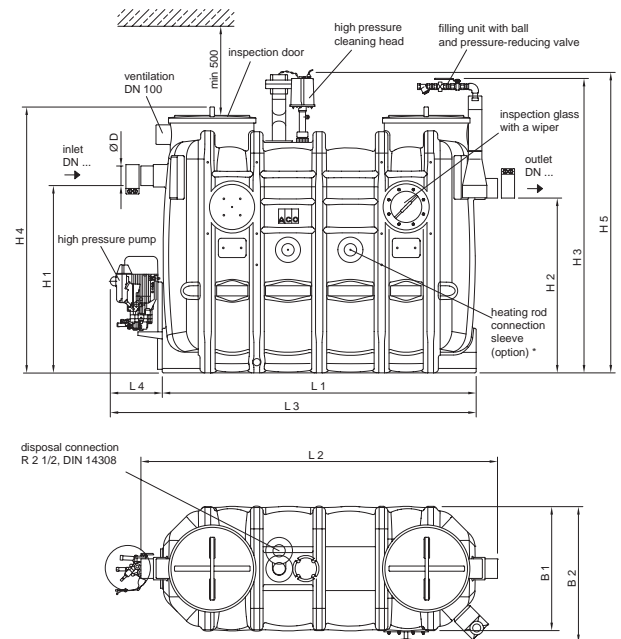

LipuJet-P-OD (Extension stage 1)

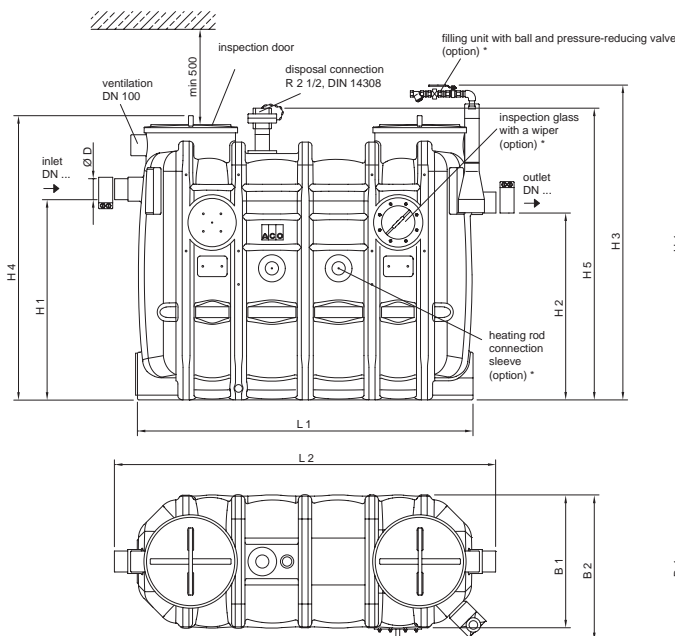

LipuJet-P-OMP (Extension stage 2 with disposal pump)

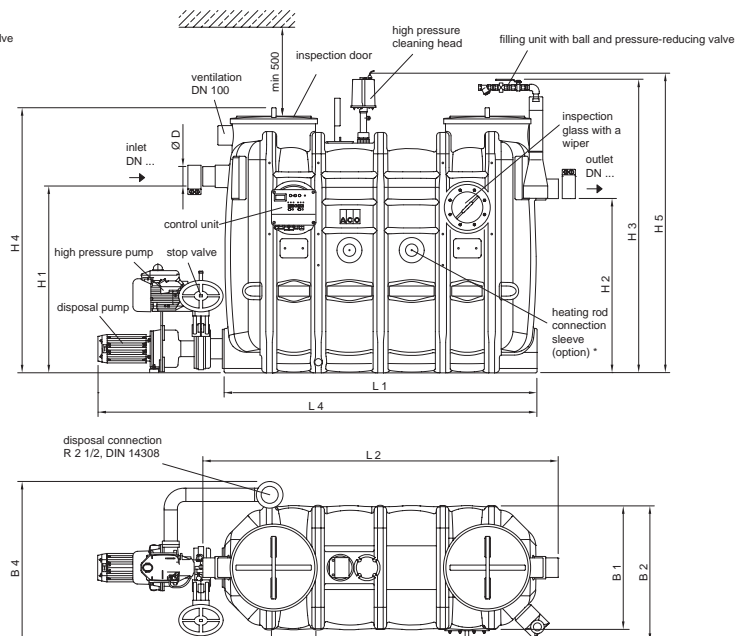

Article numbers

LipuJet-P-OA (Extension stage)

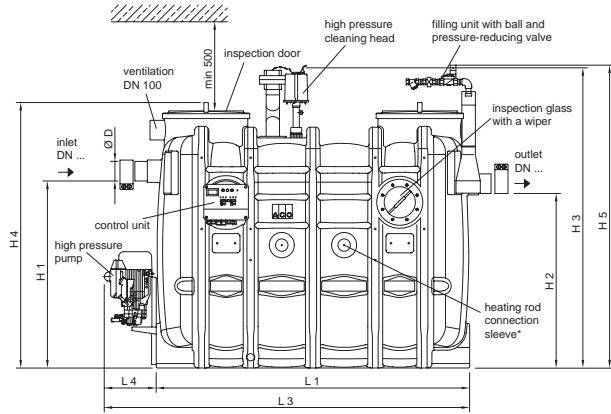

disposal connection
R 2 1/2, DIN 14308

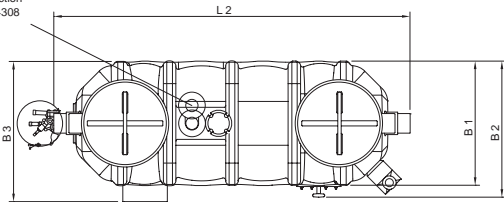

LipuJet-P-OAP (Extension stage 3 with disposal pump)

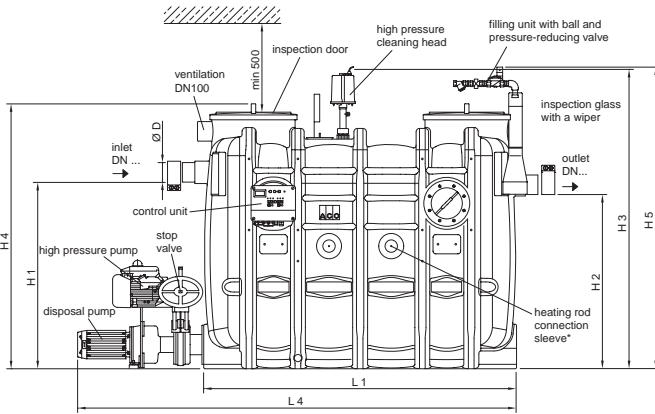

disposal connection
R 2 1/2, DIN 14308

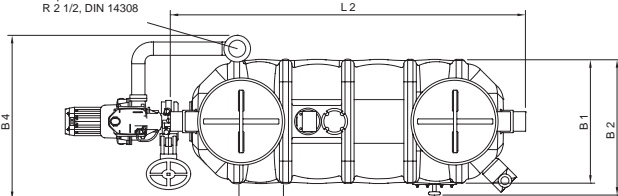







Table of dimensions: Page 27

		
NS	LipuJet-P-OB basic model	LipuJet-P-OD Extension stage 1
1	3551.34.00	3551.64.00
2	3552.34.00	3552.64.00
3	3553.34.00	3553.64.00
4	3554.34.00	3554.64.00
5.5	3555.34.00	3555.64.00
7	3557.34.00	3557.64.00
8.5	3558.34.00	3558.64.00
10	3560.34.00	3560.64.00

				
NS	LipuJet-P-OM Extension stage 2		LipuJet-P-OMP Extension stage 2 with disposal pump	
	Operational right	Operational left	Operational right	Operational left
1	3571.74.41	3571.74.31	3571.84.41	3571.84.31
2	3572.74.41	3572.74.31	3572.84.41	3572.84.31
3	3573.74.41	3573.74.31	3573.84.41	3573.84.31
4	3574.74.41	3574.74.31	3574.84.41	3574.84.31
5.5	3575.74.41	3575.74.31	3575.84.41	3575.84.31
7	3577.74.41	3577.74.31	3577.84.41	3577.84.31
8.5	3578.74.41	3578.74.31	3578.84.41	3578.84.31
10	3580.74.41	3580.74.31	3580.84.41	3580.84.31

				
NS	LipuJet-P-OA Extension stage 3		LipuJet-P-OAP Extension stage 3 with disposal pump	
	Operational right	Operational left	Operational right	Operational left
1	3551.74.42	3551.74.32	3551.84.42	3551.84.32
2	3552.74.42	3552.74.32	3552.84.42	3552.84.32
3	3553.74.42	3553.74.32	3553.84.42	3553.84.32
4	3554.74.42	3554.74.32	3554.84.42	3554.84.32
5.5	3555.74.42	3555.74.32	3555.84.42	3555.84.32
7	3557.74.42	3557.74.32	3557.84.42	3557.84.32
8.5	3558.74.42	3558.74.32	3558.84.42	3558.84.32
10	3560.74.42	3560.74.32	3560.84.42	3560.84.32

Product overview

LipuJet-P extension stage system

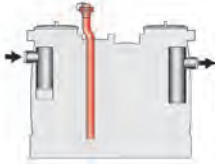
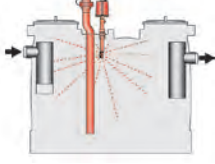
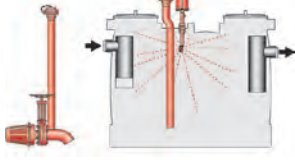
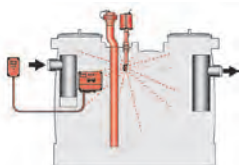
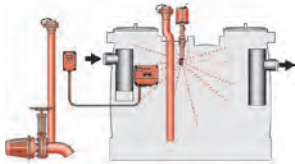
Model	Disposal		Description
	No odour nuisance	Convenience	
LipuJet-P-OB (basic model) 	—	—	<ul style="list-style-type: none"> Disposal and cleaning by opening the covers (associated with the formation of noxious smells)
LipuJet-P-OD (extension stage 1) 	✓	—	<ul style="list-style-type: none"> Odour-free disposal via a connector to direct suction After-cleaning by opening the covers (associated with the slight formation of noxious smells) Disposal connection ND 65, counter flange with fire hose quick coupling 75B and 2½" blank cap
LipuJet-P-OM (extension stage 2) 	✓	manual	<ul style="list-style-type: none"> Manual, odour-free disposal/cleaning via direct suction and hydro-mechanic high-pressure inner cleaning Disposal connection ND 65, counter flange with fire hose quick coupling 75B and 2½" blank cap Filling device with ball valve for re-filling with fresh water Hydro-mechanic inner cleaning via high-pressure pump and spray head
LipuJet-P-OMP (extension stage 2 with disposal pump) 	✓	manual	<ul style="list-style-type: none"> Identical to LipuJet-P-OM, but with additional disposal pump with free flow impeller (required for a total delivery head of over 6 metres)
LipuJet-P-OA (extension stage 3) 	✓	automatic	<ul style="list-style-type: none"> Programmed, odour-free disposal/cleaning via direct suction and hydro-mechanic high-pressure inner cleaning (175 bar) Disposal connection ND 65, counter flange with fire hose quick coupling 75B and 2½" blank cap Filling device with solenoid valve for re-filling with fresh water Hydro-mechanic inner cleaning via high-pressure pump and spray head
LipuJet-P-OAP (extension stage 3 with disposal pump) 	✓	automatic	<ul style="list-style-type: none"> Identical to LipuJet-P-OA, but with additional disposal pump with free flow impeller (required for a total delivery head of over 6 metres)

Supplementary components: Page 68 ff.

Lipujet-P – round grease separators made of polyethylene for free-standing installation



ACO Product advantages

- NS 2 – 20 transport-friendly and easy installation because can be dismantled into separate components
- Optimal and easy cleaning thanks to round shape
- Project-specific special solutions realisable with parallel modular extensions

Product information

- Grease separator plant according to EN 1825
- With integrated sludge trap
- For free-standing installation in frost-proof premises
- Inlets and outlets for connections to plastic pipes

Table of dimensions

NS	ND	Content [l]			Dimensions [mm]									Extension Dimensions [mm]			
		Sludge trap	Grease storage volume	Total	H1	H2	H3	H4	L1	L2	L3	Z/n*	D	H5	L5	L4	D1
2	100	290	120	680	975	905	1320	1370	1255	60	150	795/2	110	1520	260	260	1020
4	100	500	160	890	1240	1170	1580	1630	1255	60	150	820/2	110	1780	260	260	1020
7	150	830	400	2120	1430	1330	1880	1930	1820	60	150	785/3	160	2080	260	260	1660
10	150	1150	400	2450	1600	1500	2050	2100	1820	60	150	785/3	160	2250	260	260	1660
15	200	1950	800	3610	1765	1665	2200	2250	2130	60	150	880/3	200	2400	260	260	1915
20	200	2440	800	4070	1955	1855	2400	2400	2130	60	150	880/3	200	2600	260	260	1915

*n = number of segments

Product overview

Dimensional drawings

LipuJet-P-RB (Basic model)

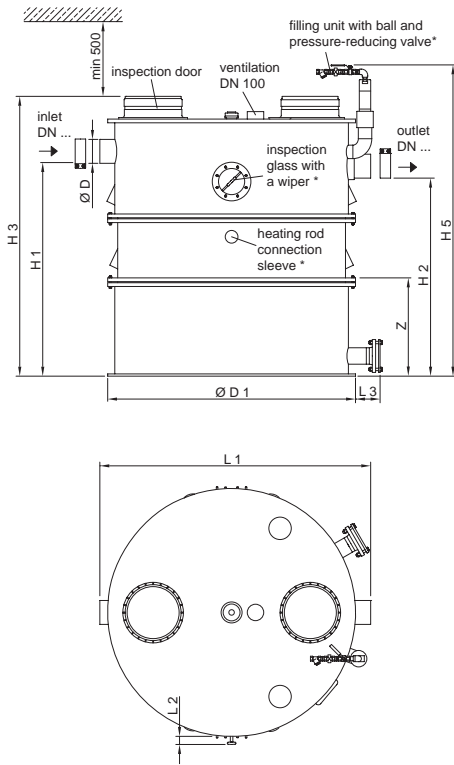

LipuJet-P-RM (Extension stage 2)

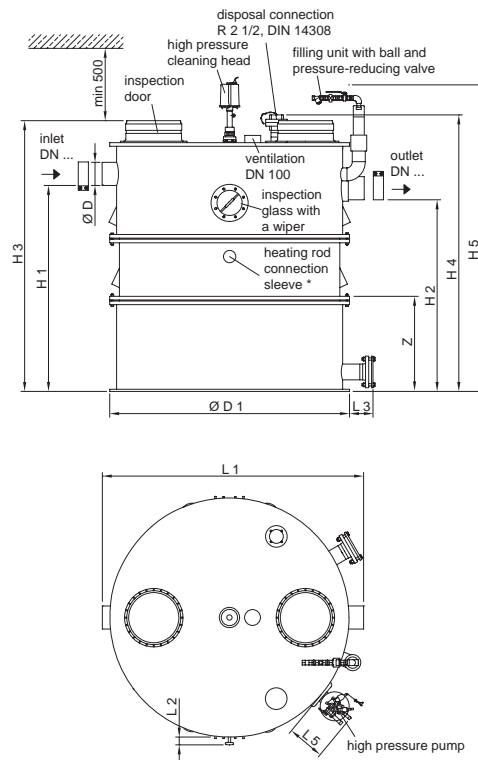

LipuJet-P-RD (Extension stage 1)

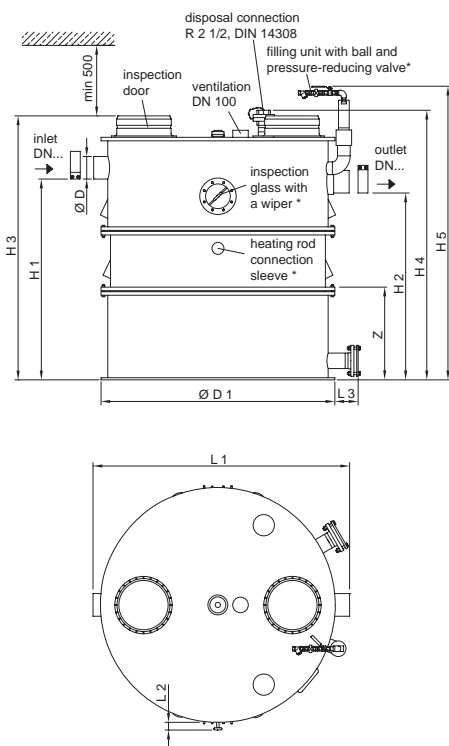

LipuJet-P-RMP (Extension stage 2 with disposal pump)

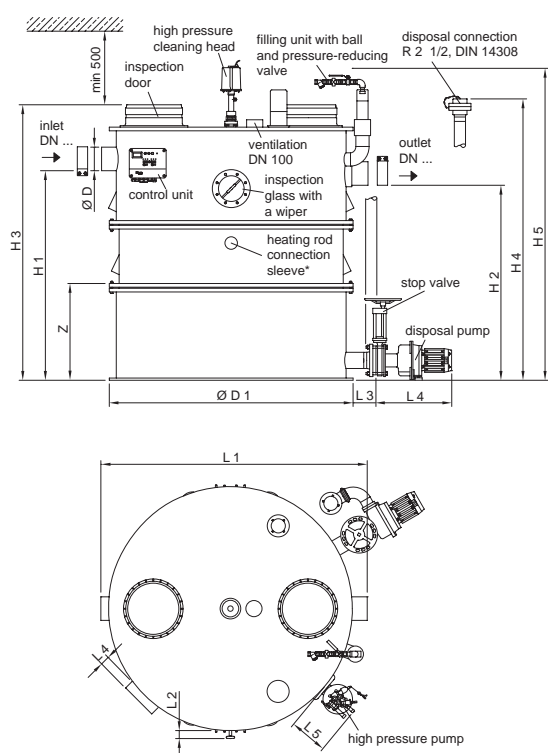

Article numbers

LipuJet-P-RA (Extension stage 3)

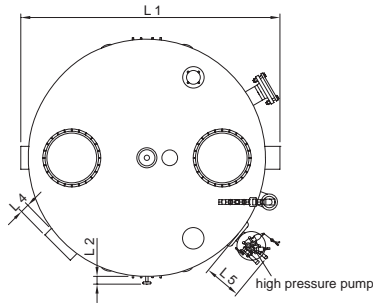
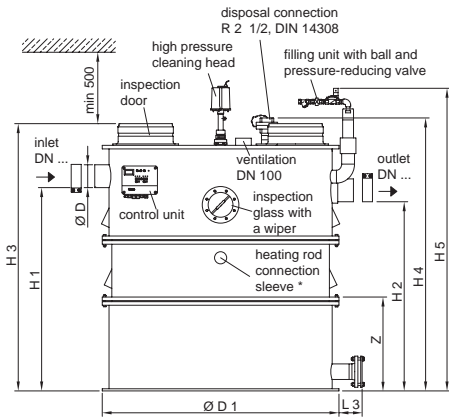

LipuJet-P-RAP (Extension stage 3 with disposal pump)

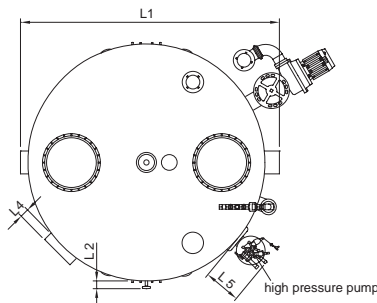
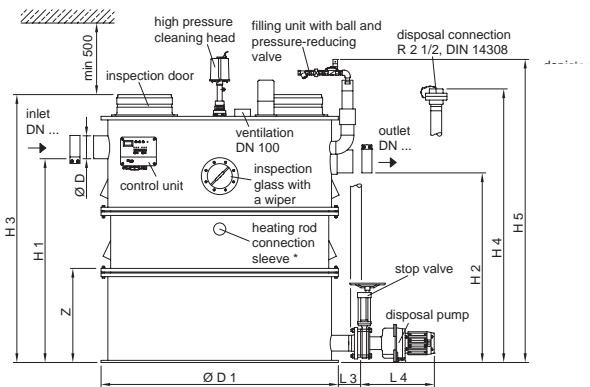







Table of dimensions: Page 41





		
NS	LipuJet-P-RB Basic model	LipuJet-P-RD Extension stage 1
2	3502.32.30	3502.62.30
4	3504.32.30	3504.62.30
7	3507.32.30	3507.62.30
10	3510.32.30	3510.62.30
15	3515.32.30	3515.62.30
20	3520.32.30	3520.62.30

				
NS	LipuJet-P-RM Extension stage 2	LipuJet-P-RMP Extension stage 2 with disposal pump		
	Operational right	Operational left	Operational right	Operational left
2	3502.73.41	3502.73.31	3502.73.81	3502.73.71
4	3504.73.41	3504.73.31	3504.73.81	3504.73.71
7	3507.73.41	3507.73.31	3507.73.81	3507.73.71
10	3510.73.41	3510.73.31	3510.73.81	3510.73.71
15	3515.73.41	3515.73.31	3515.73.81	3515.73.71
20	3520.73.41	3520.73.31	3520.73.81	3520.73.71

				
NS	LipuJet-P-RA Extension stage 3	LipuJet-P-RAP Extension stage 3 with disposal pump		
	Operational right	Operational left	Operational right	Operational left
2	3502.73.42	3502.73.32	3502.73.82	3502.73.72
4	3504.73.42	3504.73.32	3504.73.82	3504.73.72
7	3507.73.42	3507.73.32	3507.73.82	3507.73.72
10	3510.73.42	3510.73.32	3510.73.82	3510.73.72
15	3515.73.42	3515.73.32	3515.73.82	3515.73.72
20	3520.73.42	3520.73.32	3520.73.82	3520.73.72

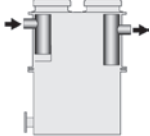
Product overview

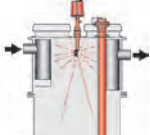
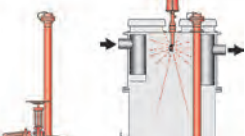
LipuJet-P extension stage system

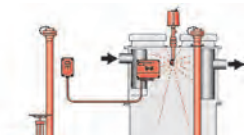
Model	Disposal		Description
	No odour nuisance	Convenience	
LipuJet-P-RB (basic model) 	—	—	<ul style="list-style-type: none"> Disposal and cleaning by opening the covers (associated with the formation of noxious smells)
LipuJet-P-RD (extension stage 1) 	✓	—	<ul style="list-style-type: none"> Odour-free disposal via a connector to direct suction After-cleaning by opening the covers (associated with the slight formation of noxious smells) Disposal connection ND 65, counter flange with fire hose quick coupling 75B and 2½" blank cap
LipuJet-P-RM (extension stage 2) 	✓	manual	<ul style="list-style-type: none"> Manual, odour-free disposal/cleaning via direct suction and hydro-mechanic high-pressure inner cleaning Disposal connection ND 65, counter flange with fire hose quick coupling 75B and 2½" blank cap Filling device with ball valve for re-filling with fresh water Hydro-mechanic inner cleaning via high-pressure pump and spray head
LipuJet-P-RMP (extension stage 2 with disposal pump) 	✓	manual	<ul style="list-style-type: none"> Identical to LipuJet-P-RM, but with additional disposal pump with free flow impeller (required for a total delivery head of over 6 metres)
LipuJet-P-RA (extension stage 3) 	✓	automatic	<ul style="list-style-type: none"> Programmed, odour-free disposal/cleaning via direct suction and hydro-mechanic high-pressure inner cleaning (175 bar) Disposal connection ND 65, counter flange with fire hose quick coupling 75B and 2½" blank cap Filling device with solenoid valve for re-filling with fresh water Hydro-mechanic inner cleaning via high-pressure pump and spray head
LipuJet-P-RAP (extension stage 3 with disposal pump) 	✓	automatic	<ul style="list-style-type: none"> Identical to LipuJet-P-RA, but with additional disposal pump with free flow impeller (required for a total delivery head of over 6 metres)

Supplementary components: Page 68 ff.

Lipujet-S – oval grease separators made of stainless steel for free-standing installation



ACO Product advantages

- Rugged construction with 25-year stability verification.
- Disposal and maintenance cost minimisation thanks to staggered nominal sizes (e.g. NS 5.5 and 8.5)
- Extension stages 2 and 3 with multi functional filling unit for high pressure internal cleaning and container filling

Product information

- Grease separator plant according to EN 1825
- For free-standing installation in frost-proof premises
- With integrated sludge trap
- Inlets and outlets for connections to plastic pipes

Table of dimensions

NS	ND	Content [l]			Dimensions [mm]									Extension Dimensions [mm]				
		Sludge trap	Grease storage volume	Total	H1	H2	H3	H4	L1	L2	B1	B2	D	H5	L3	B3	L4	B4
1	100	100	100	320	830	760	1200	1380	905	1100	635	760	110	1550	1320	370	1850	800
2	100	200	100	440	1055	985	1320	1500	905	1100	635	760	110	1700	1320	370	1850	800
3	100	300	150	630	1055	985	1320	1500	1255	1450	635	760	110	1700	1670	370	2200	800
4	100	400	200	830	1055	985	1320	1500	1605	1800	635	760	110	1700	2020	370	2550	800
5.5	150	550	360	1430	1255	1185	1570	1750	1655	1920	885	1010	160	1950	2070	550	2600	1000
7	150	700	400	1600	1255	1185	1570	1750	1855	2120	885	1010	160	1950	2270	550	2800	1000
8.5	150	850	475	1900	1255	1185	1570	1750	2155	2420	885	1010	160	1950	2570	550	3100	1000
10	150	1000	520	2000	1255	1185	1570	1750	2345	2610	885	1010	160	1950	2760	550	3300	1000

www.aco-haustechnik.de/catalogue/Article no.

All digital contents (data sheets (PDF)), dimensional drawings (DXF, IGS) and article descriptions (Datanorm, GAEB, TXT) relating to the grease separators and additional components represented here can be retrieved from the website stated above using the respective article number.

Product overview

Dimensional drawings

LipuJet-S-OB (Basic model)

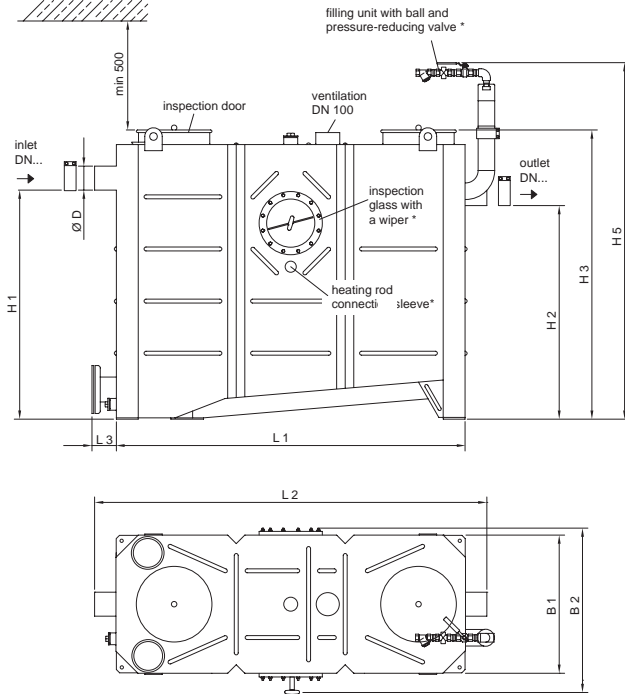

LipuJet-S-OM (Extension stage 2)

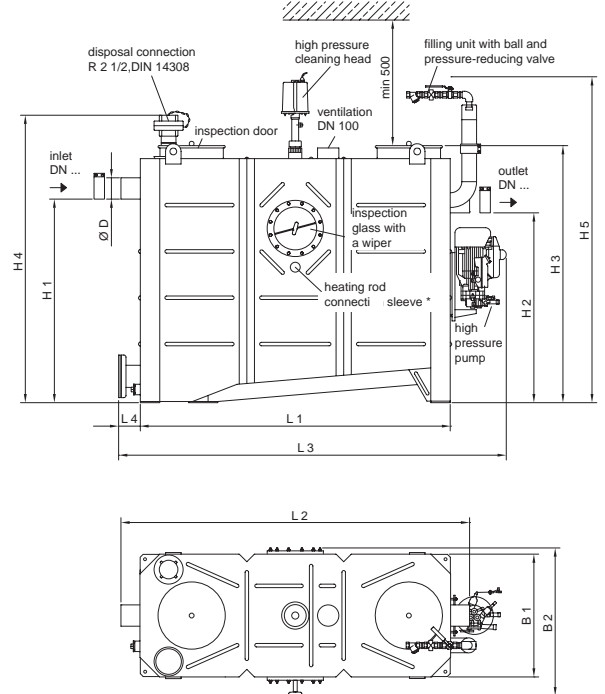

LipuJet-S-OD (Extension stage 1)

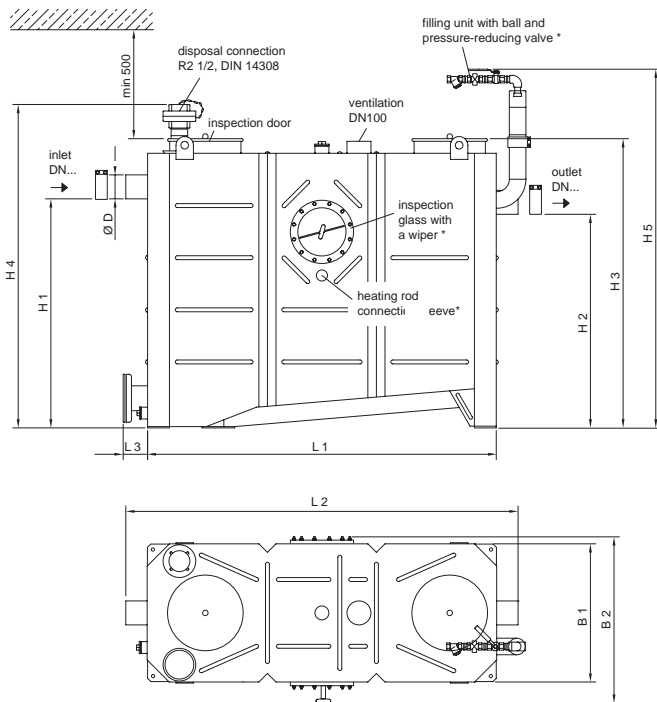

LipuJet-S-OMP (Extension stage 2 with disposal pump)

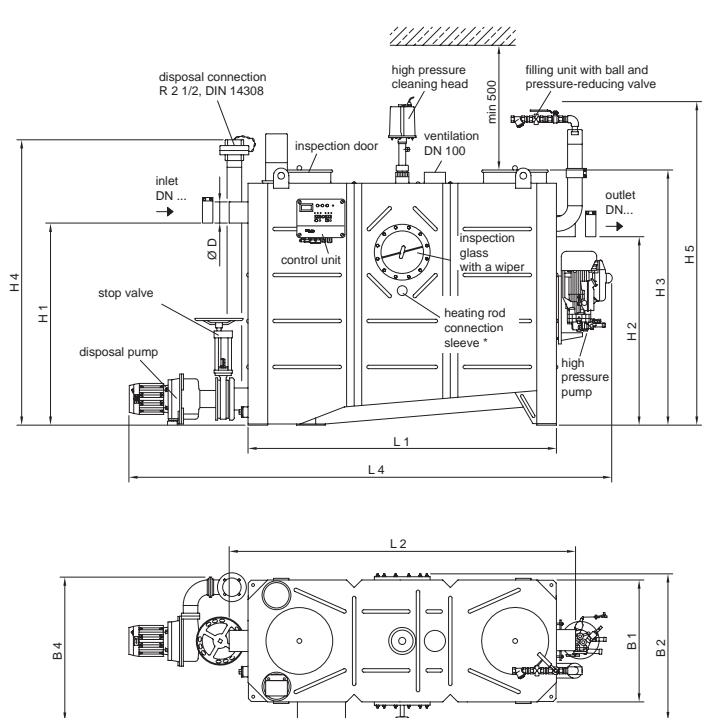

Article No.

LipuJet-S-OA (Extension stage 3)

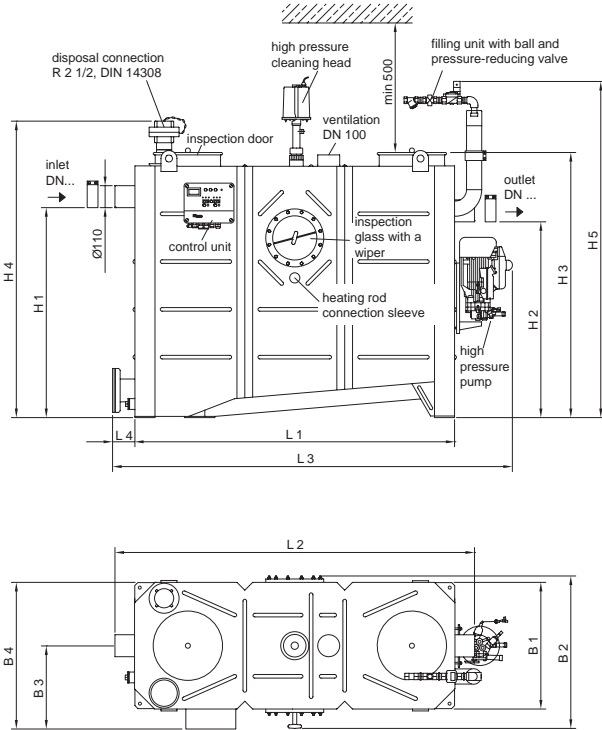

LipuJet-S-OAP (Extension stage 3 with disposal pump)

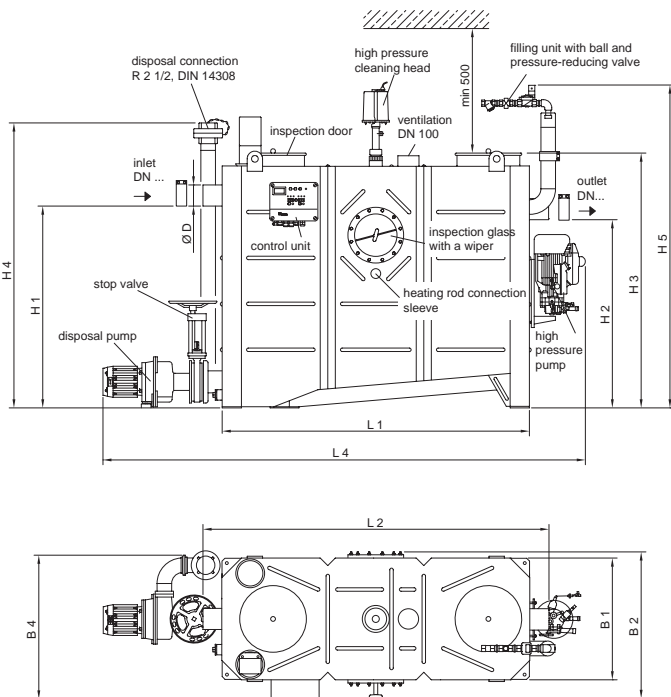





Table of dimensions: Page 25



		
NS	LipuJet-S-OB Basic model	LipuJet-S-OD Extension stage 1
1	7551.34.00	7551.64.00
2	7552.34.00	7552.64.00
3	7553.34.00	7553.64.00
4	7554.34.00	7554.64.00
5.5	7555.34.00	7555.64.00
7	7557.34.00	7557.64.00
8.5	7558.34.00	7558.64.00
10	7560.34.00	7560.64.00

				
NS	LipuJet-S-OM Extension stage 2		LipuJet-S-OMP Extension stage 2 with disposal pump	
	Operational right	Operational left	Operational right	Operational left
1	7571.74.41	7571.74.31	7571.84.41	7571.84.31
2	7572.74.41	7572.74.31	7572.84.41	7572.84.31
3	7573.74.41	7573.74.31	7573.84.41	7573.84.31
4	7574.74.41	7574.74.31	7574.84.41	7574.84.31
5.5	7575.74.41	7575.74.31	7575.84.41	7575.84.31
7	7577.74.41	7577.74.31	7577.84.41	7577.84.31
8.5	7578.74.41	7578.74.31	7578.84.41	7578.84.31
10	7580.74.41	7580.74.31	7580.84.41	7580.84.31

				
NS	LipuJet-S-OA Extension stage 3		LipuJet-S-OAP Extension stage 3 with disposal pump	
	Operational right	Operational left	Operational right	Operational left
1	7571.74.42	7571.74.32	7571.84.42	7571.84.32
2	7572.74.42	7572.74.32	7572.84.42	7572.84.32
3	7573.74.42	7573.74.32	7573.84.42	7573.84.32
4	7574.74.42	7574.74.32	7574.84.42	7574.84.32
5.5	7575.74.42	7575.74.32	7575.84.42	7575.84.32
7	7577.74.42	7577.74.32	7577.84.42	7577.84.32
8.5	7578.74.42	7578.74.32	7578.84.42	7578.84.32
10	7580.74.42	7580.74.32	7580.84.42	7580.84.32

Product overview

LipuJet-S extension stage system

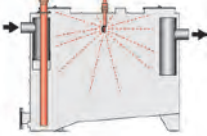
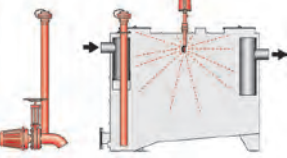
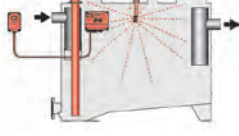
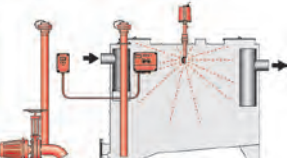
Model	Disposal		Description
	No odour nuisance	Convenience	
LipuJet-S-OB (basic model) 	—	—	<ul style="list-style-type: none"> Disposal and cleaning by opening the covers (associated with the formation of noxious smells)
LipuJet-S-OD (extension stage 1) 	✓	—	<ul style="list-style-type: none"> Odour-free disposal via a connector to direct suction After-cleaning by opening the covers (associated with the slight formation of noxious smells) Disposal connection ND 65, counter flange with fire hose quick coupling 75B and 2½" blank cap
LipuJet-S-OM (extension stage 2) 	✓	manual	<ul style="list-style-type: none"> Manual, odour-free disposal/cleaning via direct suction and hydro-mechanic high-pressure inner cleaning Disposal connection ND 65, counter flange with fire hose quick coupling 75B and 2½" blank cap Filling device with ball valve for re-filling with fresh water Hydro-mechanic inner cleaning via high-pressure pump and spray head
LipuJet-S-OMP (extension stage 2 with disposal pump) 	✓	manual	<ul style="list-style-type: none"> Identical to LipuJet-S-OM, but with additional disposal pump with free flow impeller (required for a total delivery head of over 6 metres)
LipuJet-S-OA (extension stage 3) 	✓	automatic	<ul style="list-style-type: none"> Programmed, odour-free disposal/cleaning via direct suction and hydro-mechanic high-pressure inner cleaning (175 bar) Disposal connection ND 65, counter flange with fire hose quick coupling 75B and 2½" blank cap Filling device with solenoid valve for re-filling with fresh water Hydro-mechanic inner cleaning via high-pressure pump and spray head
LipuJet-S-OAP (extension stage 3 with disposal pump) 	✓	automatic	<ul style="list-style-type: none"> Identical to LipuJet-S-OA, but with additional disposal pump with free flow impeller (required for a total delivery head of over 6 metres)

Supplementary components: Page 68 ff.

LipuleJet-S – round grease separators made of stainless steel for free-standing installation



ACO Product advantages

- NS 2 – 20 transport-friendly and easy installation because can be dismantled into separate components
- Optimal and easy cleaning thanks to round shape
- Project-specific special solutions realisable with parallel modular extensions

Product information

- Grease separator plant according to EN 1825
- With integrated sludge trap
- For free-standing installation in frost-proof premises
- Inlets and outlets for connections to plastic pipes

Table of dimensions

NS	ND	Content [l]			Dimensions [mm]								Extension Dimensions [mm]			
		Sludge trap	Grease storage volume	Total	H1	H2	H3	H4	L1	L2	Z/n*	D	H5	L5	L4	D1
2	100	210	120	715	975	905	1200	1400	1180	120	785/2	110	1520	250	110	1000
4	100	420	165	915	1240	1170	1450	1650	1180	120	785/2	110	1770	250	110	1000
7	150	705	400	1950	1430	1330	1780	1930	1800	120	790/3	160	2100	250	110	1500
10	150	1000	400	2250	1600	1500	1950	2100	1800	120	790/3	160	2270	250	110	1500
15	200	1630	800	3350	1755	1685	2120	2250	2050	120	820/3	210	2440	250	110	1750
20	200	2110	800	3820	1935	1885	2320	2450	2050	120	820/3	210	2640	250	110	1750

*n = number of segments

www.aco-haustechnik.de/catalogue/Article no.

All digital contents (data sheets (PDF)), dimensional drawings (DXF, IGS) and article descriptions (Data-norm, GAEB, TXT) relating to the grease separators and additional components represented here can be retrieved from the website stated above using the respective article number.

Product overview

Dimensional drawings

LipJet-S-RB (Basic model)

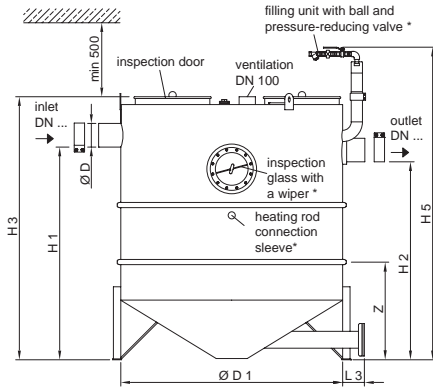

LipJet-S-RM (Extension stage 2)

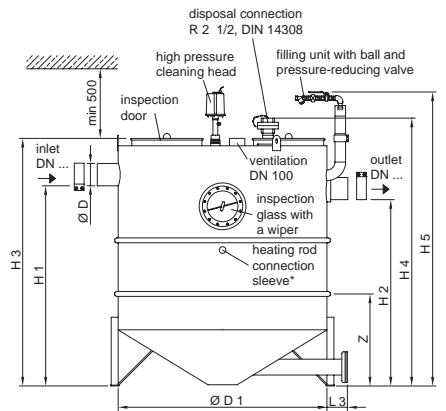

LipJet-S-RD (Extension stage 1)

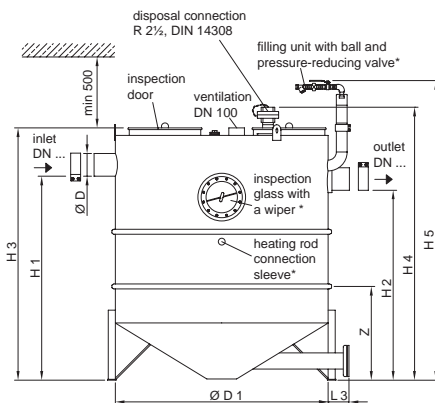

LipJet-S-RA (Extension stage 3)

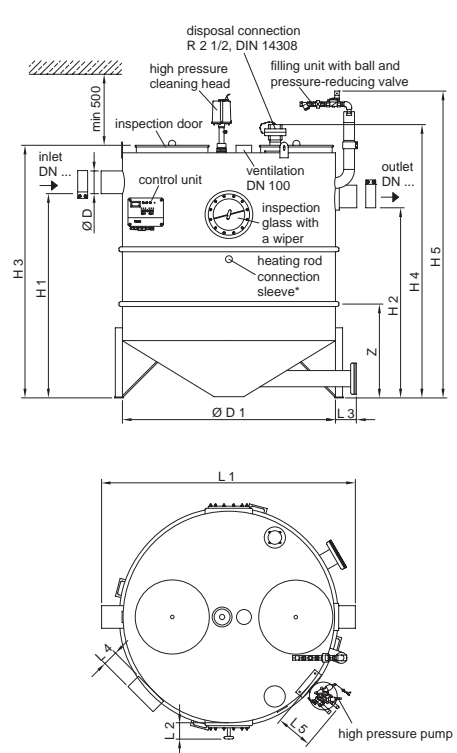



Article numbers

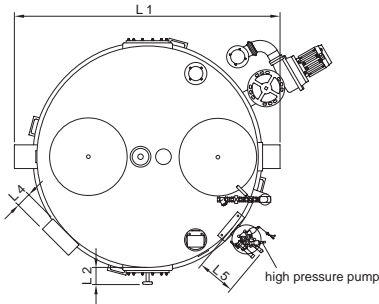
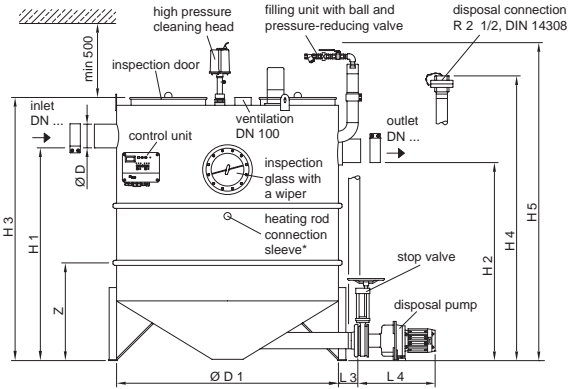

LipuJet-S-RMP (Extension stage 2 with disposal pump)

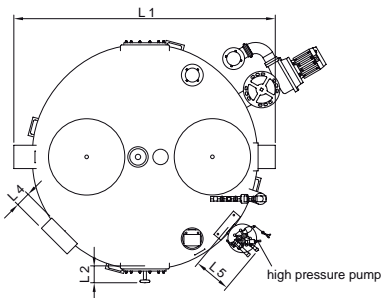
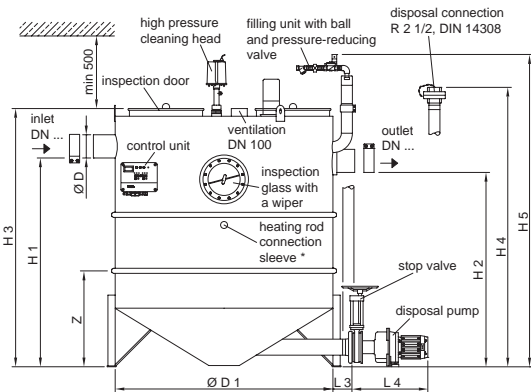



LipuJet-S-RAP (Extension stage 3 with disposal pump)





		
NS	LipuJet-S-RB Basic model	LipuJet-S-RD Extension stage 1
2	7502.32.00	7502.62.00
4	7504.32.00	7504.62.00
7	7507.32.00	7507.62.00
10	7510.32.00	7510.62.00
15	7515.32.00	7515.62.00
20	7520.32.00	7520.62.00

				
NS	LipuJet-S-RM Extension stage 2		LipuJet-S-RMP Extension stage 2 with disposal pump	
	Operational right	Operational left	Operational right	Operational left
2	7502.73.41	7502.73.31	7502.73.61	7502.73.51
4	7504.73.41	7504.73.31	7504.73.61	7504.73.51
7	7507.73.41	7507.73.31	7507.73.61	7507.73.51
10	7510.73.41	7510.73.31	7510.73.61	7510.73.51
15	7515.73.41	7515.73.31	7515.73.61	7515.73.51
20	7520.73.41	7520.73.31	7520.73.61	7520.73.51

				
NS	LipuJet-S-RA Extension stage 3		LipuJet-S-RAP Extension stage 3 with disposal pump	
	Operational right	Operational left	Operational right	Operational left
2	7502.73.42	7502.73.32	7502.73.62	7502.73.52
4	7504.73.42	7504.73.32	7504.73.62	7504.73.52
7	7507.73.42	7507.73.32	7507.73.62	7507.73.52
10	7510.73.42	7510.73.32	7510.73.62	7510.73.52
15	7515.73.42	7515.73.32	7515.73.62	7515.73.52
20	7520.73.42	7520.73.32	7520.73.62	7520.73.52

Product overview

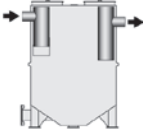
LipuJet-S extension stage system

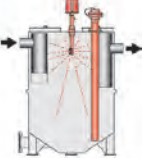
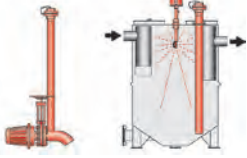
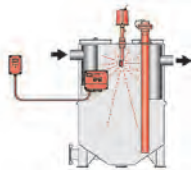
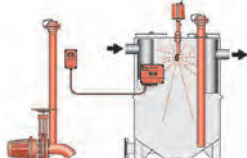
Model	Disposal		Description
	No odour nuisance	Convenience	
LipuJet-S-RB (Basic model) 	—	—	<ul style="list-style-type: none"> ■ Disposal and cleaning by opening the covers (associated with the formation of noxious smells)
LipuJet-S-RD (Extension stage 1) 	✓	—	<ul style="list-style-type: none"> ■ Odour-free disposal via a connector to direct suction ■ After-cleaning by opening the covers (associated with the slight formation of noxious smells) ■ Disposal connection ND 65, counter flange with fire hose quick coupling 75B and 2½" blank cap
LipuJet-S-RM (Extension stage 2) 	✓	manual	<ul style="list-style-type: none"> ■ Manual, odour-free disposal/cleaning via direct suction and hydro-mechanic high-pressure inner cleaning ■ Disposal connection ND 65, counter flange with fire hose quick coupling 75B and 2½" blank cap ■ Filling device with ball valve for re-filling with fresh water ■ Hydro-mechanic inner cleaning via high-pressure pump and spray head
LipuJet-S-RMP (Extension stage 2 with disposal pump) 	✓	manual	<ul style="list-style-type: none"> ■ As before, but with additional disposal pump with free flow impeller (required for a total delivery head of over 6 metres)
LipuJet-S-RA (Extension stage 3) 	✓	automatic	<ul style="list-style-type: none"> ■ Programmed, odour-free disposal/cleaning via direct suction and hydro-mechanic high-pressure inner cleaning (175 bar) ■ Disposal connection ND 65, counter flange with fire hose quick coupling 75B and 2½" blank cap ■ Filling device with solenoid valve for re-filling with fresh water ■ Hydro-mechanic inner cleaning via high-pressure pump and spray head
LipuJet-S-RAP (Extension stage 3 with disposal pump) 	✓	automatic	<ul style="list-style-type: none"> ■ As before, but with additional disposal pump with free flow impeller (required for a total delivery head of over 6 metres)

Supplementary components: Page 68 ff.

Lipujet-P-SB – split-design grease separators for free-standing installation



ACO Product advantages

- Very useful in applications with narrow access routes because can be split into three parts
- Easy to transport and assemble

Product information

- Grease separator plant according to EN 1825
- For indoor installation – frost-free
- With separate sludge trap
- Odour-proof maintenance opening, diameter: 450 mm
- Inlets and outlets for connections to plastic pipes

Dimensional drawing

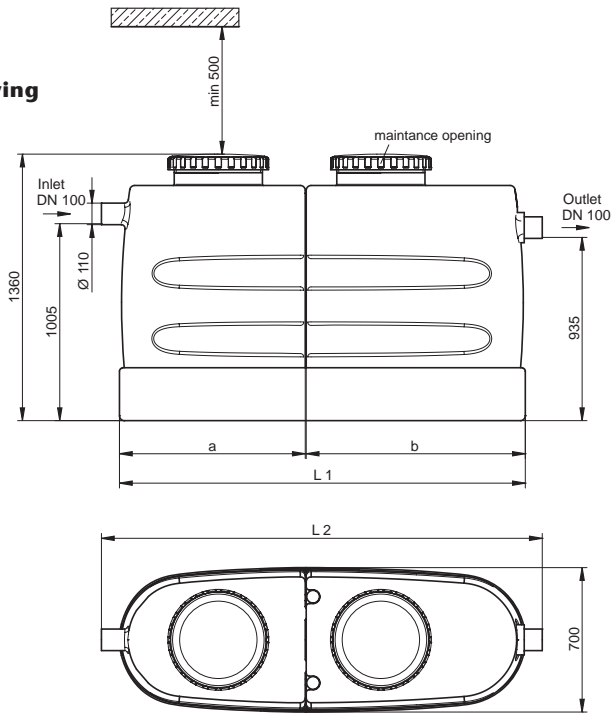

Table of dimensions

NS	Content [l]			Dimensions [mm]				Weight [kg]		Article No.
	Sludge trap	Grease storage volume	Total	L1	L2	a	b	empty	full	
2	210	80	480	1180	1360	510	660	75	555	3802.00.00
4	420	160	880	2070	2250	945	1115	115	995	3804.00.00

Product overview

LipuJet-P-SD – split-design grease separators for free-standing installation with direct suction extraction



ACO Product advantages

- Very useful in applications with narrow access routes because can be split into three parts
- Easy to transport and assemble
- Integrated suction extraction pipe to reduce odour-emissions during disposal

The figure shows nominal size 4 – the sampling pipe and the lifting plant must be ordered separately.

Product information

- Grease separator plant according to EN 1825
- For indoor installation – frost-free
- With separate sludge trap
- With draining connection ND 50 and fire hose quick coupling B 2"
- Suction and emptying sump with drain plug socket 1"
- Odour-proof maintenance opening, diameter: 450 mm
- Inlets and outlets for connections to plastic pipes

Dimensional drawing

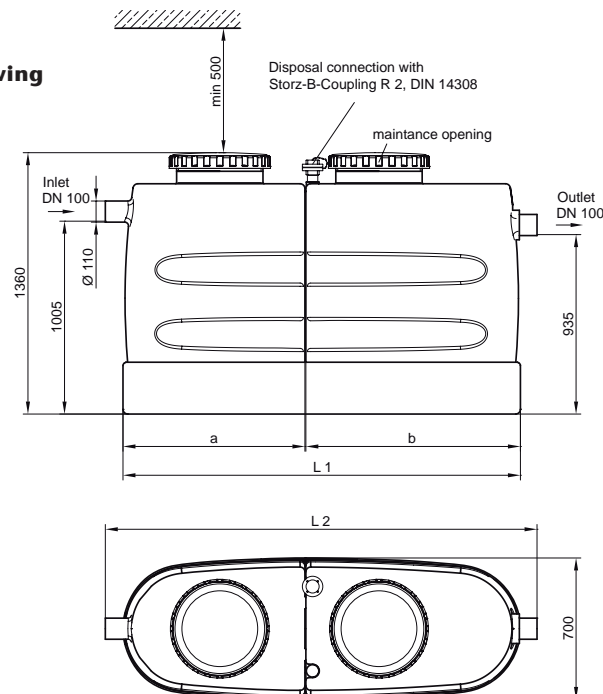

Table of dimensions

NS	Content [l]			Dimensions [mm]				Weight [kg]		Article No.
	Sludge trap	Grease storage volume	Total	L1	L2	a	b	empty	full	
2	210	80	480	1180	1360	510	660	75	555	3802.50.00
4	420	160	880	2070	2250	945	1115	115	995	3804.50.00

Lipujet-P-OAP oval grease separator made of polyethylene for free standing installation



ACO Product advantages

- With two inspection windows for sludge and grease control
- With two high pressure spray heads for perfect inner body cleaning
- Disposal pump for maximum lift heights up to 18 meters with 10 m³/h disposal performance
- Control unit with presets and flexible adjustments (cleaning and filling times)

Product information

- Grease separator plant according to EN 1825 for free-standing installation in frost proof rooms
- Manufactured of welded polyethylene in oval shape
- Two odour proof maintenance openings OD 450 mm
- Inlet and outlet for plastic pipe connection
- Two inspection windows with wiper for grease and sludge control
- Automatically operated disposal pump 3,7 kW with shut-off valve, disposal connection OD 75 mm and coupling Storz B R 2 1/2"
- Two automatically operated high pressure pumps 3,9 kW and high pressure spray heads with 150 bar for crushing and mixing of separator contents and cleaning of separator body
- Automatically operated filling device R 3/4" (solenoid valve)
- Electric connection 400 V / 50 Hz / 16 A / 11,5 kW

Dimensional drawing

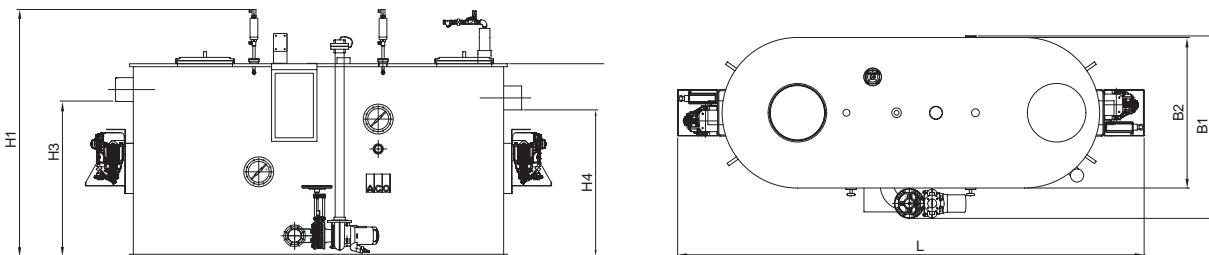

Table of dimensions

NS	Inlet/outlet OD [mm]	Sludge trap [l]	Grease storage [l]	Total capacity [l]	Dimensions [mm]							Article No. Operating side right	Article No. Operating side left
					L	B1	B2	H1	H2	H3	H4		
15	200	1580	630	2850	3210	1530	1340	2090	1640	1300	1230	3815.85.42	3815.85.32
20	200	2070	850	3760	3910	1530	1340	2090	1640	1300	1230	3820.85.42	3820.85.32
25	200	2550	1070	4660	4610	1530	1340	2190	1740	1300	1230	3825.85.42	3825.85.32
30	250	3020	1290	5550	5310	1530	1340	2190	1740	1300	1230	3830.85.42	3830.85.32

Product overview

LipuJet-P-OAP oval grease separator made of polyethylene for free standing installation



ACO Product advantages

- Each separator with two inspection windows for sludge and grease control
- Each separator with two high pressure spray heads for perfect inner body cleaning
- Each separator with disposal pump for maximum lift heights up to 18 meters with 10 m³/h disposal performance
- Each separator with control unit with presets and flexible adjustments (cleaning and filling times)

Product information

- Grease separator plant according to EN 1825 for free-standing installation in frost proof rooms
- In parallel installation, with distribution unit inlet OD 250 mm, piping and two manual valves between distribution unit and separators
- Manufactured of welded polyethylene in oval shape
- Two odour proof (each separator) maintenance openings OD 450 mm
- Inlet and outlet for plastic pipe connection
- Two inspection windows (each separator) with wiper for grease and sludge control
- Automatically operated disposal pump 3,7 kW with shut-off valve, disposal connection OD 75 mm and coupling Storz B R 2½" for each separator
- Two automatically operated high pressure pumps 3,9 kW and high pressure spray heads with 150 bar for crushing and mixing of separator contents and cleaning of separator body for each separator
- Automatically operated filling device R ¾" (solenoid valve) for each separator
- Electric connection 400 V / 50 Hz / 16 A / 11,5 kW for each separator

Dimensional drawing

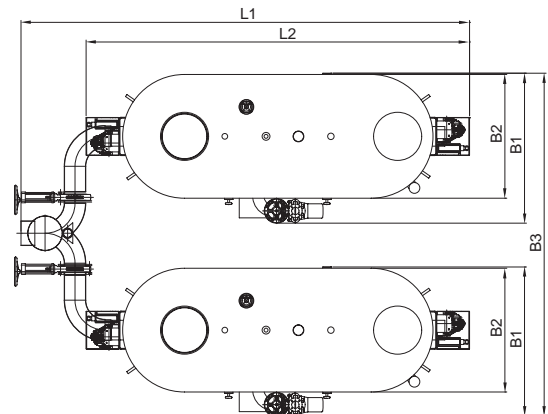
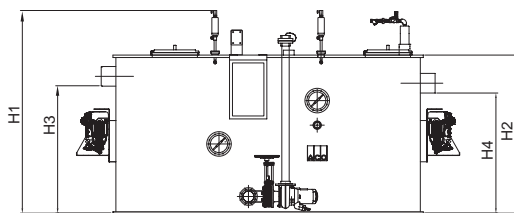

Table of dimensions

NS	Inlet/ outlet OD [mm]	Sludge trap [l]	Grease storage [l]	Total capacity [l]	Dimensions [mm]								Article No. Operating side right
					L	B1	B2	B3	H1	H2	H3	H4	
40	200	4140	1700	7520	3910	1530	1340	3500	2090	1640	1300	1230	3840.85.42
50	200	5100	2140	9320	4610	1530	1340	3500	2190	1740	1300	1230	3850.85.42
60	250	6040	2580	11100	5310	1530	1340	3500	2190	1740	1300	1230	3860.85.42

Lipujet-P-OA oval grease separator made of polyethylene for free standing installation



ACO Product advantages

- With two inspection windows for sludge and grease control
- With two high pressure spray heads for perfect inner body cleaning
- Control unit with presets and flexible adjustments (cleaning and filling times)

Product information

- Grease separator plant according to EN 1825 for free-standing installation in frost proof rooms
- Manufactured of welded polyethylene in oval shape
- Two odour proof maintenance openings OD 450 mm
- Inlet and outlet for plastic pipe connection
- Two inspection windows with wiper for grease and sludge control
- Disposal connection OD 75 mm and coupling Storz B R 2½"
- Two automatically operated high pressure pumps 3,9 kW and high pressure spray heads with 150 bar for crushing and mixing of separator contents and cleaning of separator body
- Automatically operated filling device R ¾" (solenoid valve)
- Electric connection 400 V / 50 Hz / 16 A / 7,8 kW

Dimensional drawing

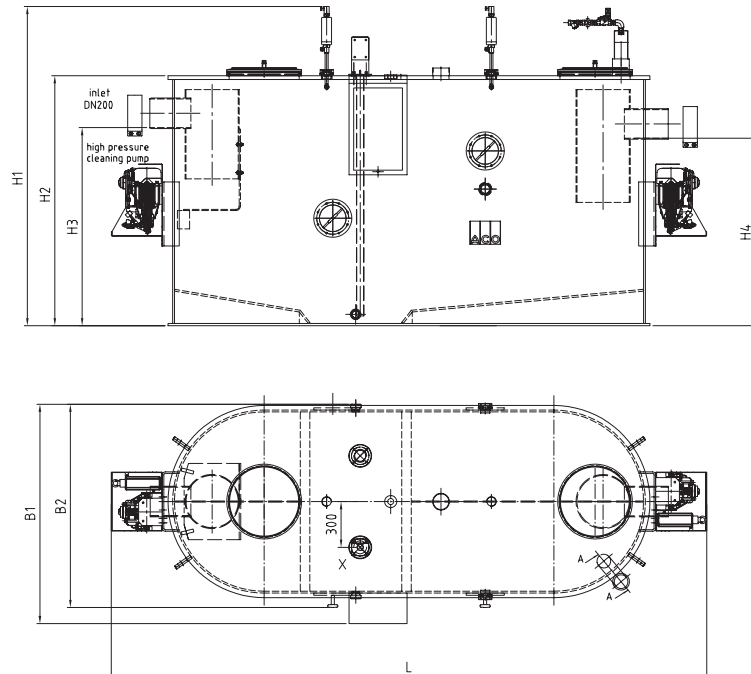

Table of dimensions

NS	Inlet/outlet OD [mm]	Sludge trap [l]	Grease storage [l]	Total capacity [l]	Dimensions [mm]								Article No. Operating side right	Article No. Operating side left
					L	B1	B2	H1	H2	H3	H4			
15	200	1580	630	2850	3210	1530	1340	2090	1640	1300	1230	3815.75.42	3815.75.32	
20	200	2070	850	3760	3910	1530	1340	2090	1640	1300	1230	3820.75.42	3820.75.32	
25	200	2550	1070	4660	4610	1530	1340	2190	1740	1300	1230	3825.75.42	3825.75.32	
30	250	3020	1290	5550	5310	1530	1340	2190	1740	1300	1230	3830.75.42	3830.75.32	

Parallel devices on request

Product overview

LipuJet-P-OD oval grease separator made of polyethylene for free standing installation



ACO Product advantages

- With two inspection windows for sludge and grease control
- Optionally with filling device
- Optionally with grease level sensor

Product information

- Grease separator plant according to EN 1825 for free-standing installation in frost proof rooms
- Manufactured of welded polyethylene in oval shape
- Two odour proof maintenance openings OD 450 mm
- Inlet and outlet for plastic pipe connection
- Two inspection windows with wiper for grease and sludge control
- Disposal connection OD 75 mm and coupling Storz B R 2½"

Dimensional drawing

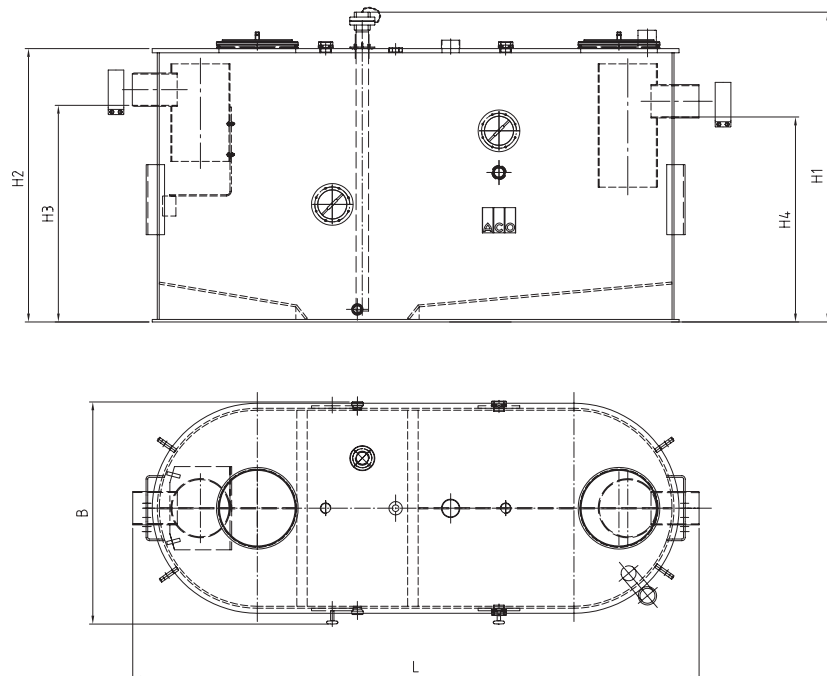

Table of dimensions

NS	Inlet/ outlet OD [mm]	Sludge trap [l]	Grease storage [l]	Total capacity [l]	Dimensions [mm]						Article No. Operating side right	Article No. Operating side left
					L	B	H1	H2	H3	H4		
15	200	1580	630	2850	3210	1340	1850	1640	1300	1230	3815.45.42	3815.45.32
20	200	2070	850	3760	3910	1340	1850	1640	1300	1230	3820.45.42	3820.45.32
25	200	2550	1070	4660	4610	1340	1950	1740	1300	1230	3825.45.42	3825.45.32
30	250	3020	1290	5550	5310	1340	1950	1740	1300	1230	3830.45.42	3830.45.32

Parallel devices on request

Lipujet-P-OB oval grease separator made of polyethylene for free standing installation



ACO Product advantages

- With two inspection windows for sludge and grease control
- Optionally with filling device
- Optionally with grease level sensor

Product information

- Grease separator plant according to EN 1825 for free-standing installation in frost proof rooms
- Manufactured of welded polyethylene in oval shape
- Two odour proof maintenance openings OD 450 mm
- Inlet and outlet for plastic pipe connection
- Two inspection windows with wiper for grease and sludge control

Dimensional drawing

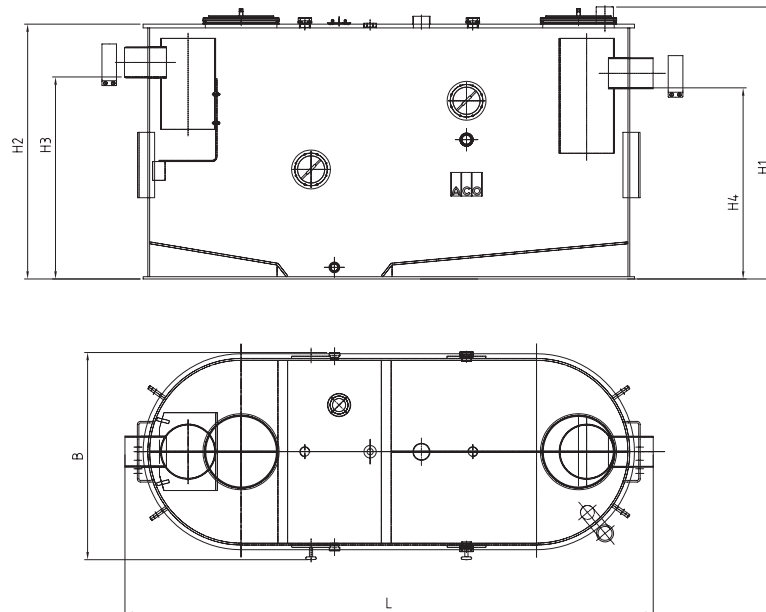

Table of dimensions

NS	Inlet/ outlet OD [mm]	Sludge trap [l]	Grease storage [l]	Total capacity [l]	Dimensions [mm]						Article No. Operating side right	Article No. Operating side left
					L	B	H1	H2	H3	H4		
15	200	1580	630	2850	3210	1340	1750	1640	1300	1230	3815.35.42	3815.35.32
20	200	2070	850	3760	3910	1340	1750	1640	1300	1230	3820.35.42	3820.35.32
25	200	2550	1070	4660	4610	1340	1850	1740	1300	1230	3825.35.42	3825.35.32
30	250	3020	1290	5550	5310	1340	1850	1740	1300	1230	3830.35.42	3830.35.32

Parallel devices on request

Product overview

Lipumobil-P grease separator made of polyethylene for mobile use



ACO Product advantages

- Easy to erect thanks to low weight and compact dimensions
- Odour-proof manhole cover
- Simple emptying and cleaning
- Flexible connection options

Product information

- Grease separator for the following fields of application:
 - Mobile snack bars
 - Mobile dishwashers
 - Occasional meal preparation
- Can only be used with
 - Connection of 1 commercial dishwasher with a minimum washing time of 1 min with a change-over time of ½ min (total cycle time $t_z = 1\frac{1}{2}$ min)
 - Rinsing water consumption of the commercial dishwasher $v_s = 5$ l
- Alongside the dishwasher, max. 1 item of equipment for pre-rinsing the dishes (briefly) can be connected
- Made of polyethylene
- For mobile rinse units (no fixed installation)
- With integrated sludge trap
- For free-standing installation in frost-proof areas
- Plug cap for type 0.3
 - Polyethylene
 - Diameter: 350 mm
- Cover for type 0.5
 - Polyethylene
 - Diameter: 450 mm
 - With tension ring

Dimensional drawing

Lipumobil-P type 0.3

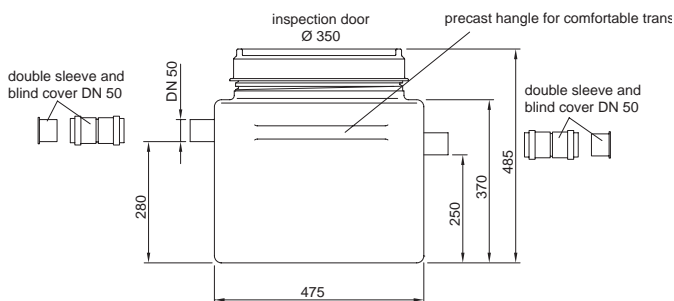

Lipumobil-P type 0.5

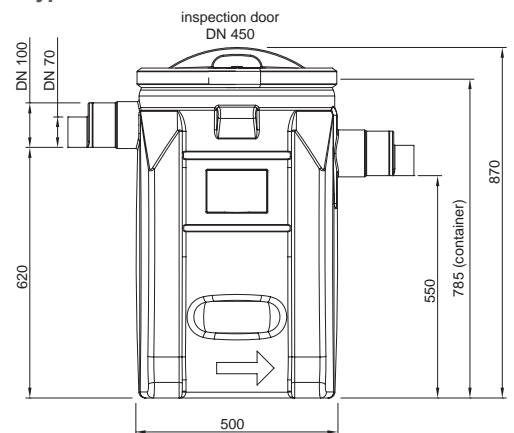

Table of dimensions

NS	Contents [l]			Weight [kg]		Article no.
	Sludge trap	Grease storage volume	Total	empty	full	
0.3	10	9	32	10	42	3700.01.00
0.5	50	20	100	19	119	3700.02.00

LipuMobil-S grease separator made of stainless steel for mobile use



ACO Product advantages

- Easy to erect thanks to low weight and compact dimensions
- Odour-proof manhole cover
- Simple emptying and cleaning

Product information

- Grease separator for the following fields of application:
 - Mobile snack bars
 - Mobile dishwashers
- Can only be used with
 - Connection of 1 commercial dishwasher with a minimum washing time of 1 min with a change-over time of ½ min (total cycle time $t_z = 1\frac{1}{2}$ min)
 - Rinsing water consumption of the commercial dishwasher $v_s = 5$ l
 - Alongside the dishwasher, max. 1 item of equipment for pre-rinsing the dishes (briefly) can be connected
- Made of stainless steel, material grade 316
- For mobile rinse units
- With integrated sludge trap
- For free-standing installation in frost-proof areas
- Cover with locking ring
 - Diameter: 350 mm

Dimensional drawing

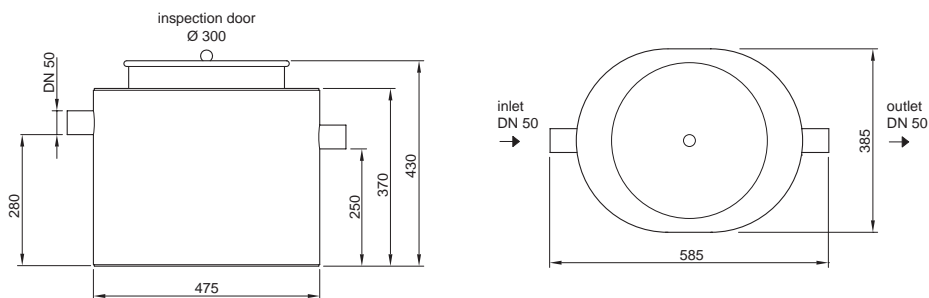

Table of dimensions

NS	Contents [l]			Weight [kg]		Article no.
	Sludge trap	Grease storage volume	Total	empty	full	
0.3	50	10	9	20	52	7301.30.40

Product overview

Lipator-P-RM



ACO Product advantages

- Compact footprint dimensions for small applications
- Easy handling and insertion
- Self-explaining and illuminated control box

Product information

- Grease separator according to EN 1825 for partial disposal of grease and sludge
- For installation in frost-free premises
- With integrated sludge trap
- Manufactured of polyethylen
- Inlet and outlet connections as per EN 877 with OD 110 mm
- With manual valves ND 50 for grease and sludge extraction
- Optionally with heating rod and control unit 1.5 kW, 230 V/50+60 Hz

Dimensions

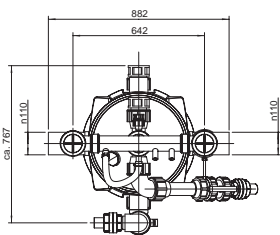
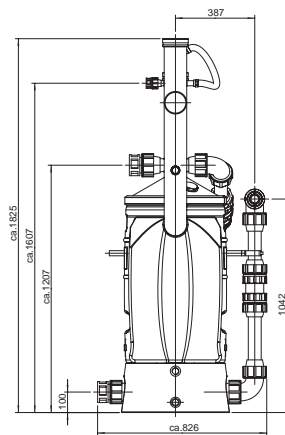
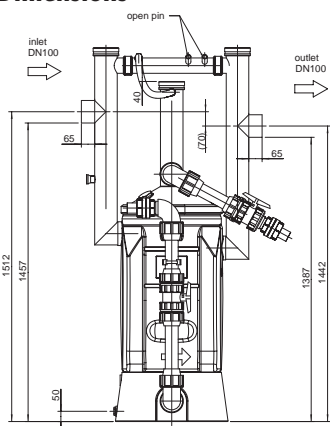

Order information

NS	Heating rod and control	Flow rate [m³/h]	Total capacity [l]	Weight empty [kg]	Article No.
1	With	3.6	120	30	3570.40.10
1	Without	3.6	120	25	3570.40.00
Operating set consisting of four barrels and two connecting sets					0170.30.35
Retrofit set for pressure increase					0170.29.87

Lipator-P-OM



ACO Product advantages

- Compact footprint dimensions for small applications
- Easy handling and insertion
- Self-explaining and illuminated control box

Product information

- Grease separator according to EN 1825 for partial disposal of grease and sludge
- For installation in frost-free premises
- With integrated sludge trap
- Manufactured of polyethylene
- Inlet and outlet connections as per EN 877 with OD 110 mm
- With manual valves ND 50 for grease and sludge extraction
- Optionally with heating rod and control unit 1.5 kW, 230 V/50+60 Hz

Dimensions

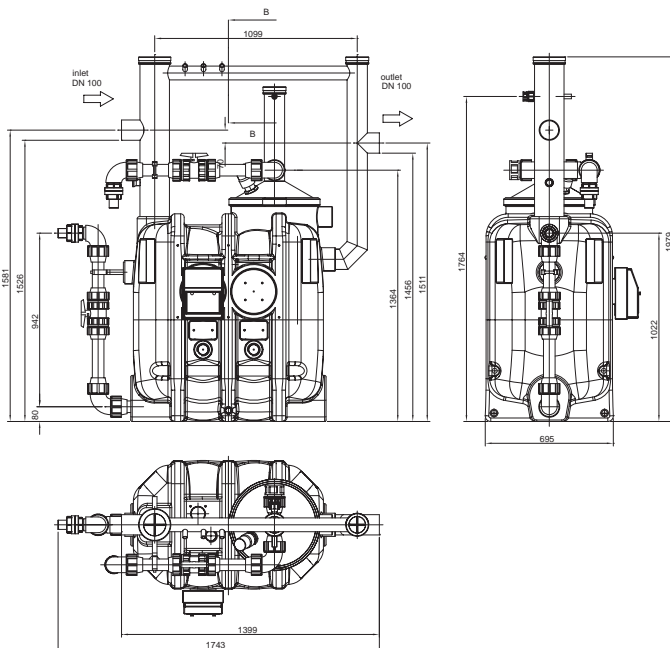

Order information

NS	Heating rod and control	Flow rate [m ³ /h]	Total capacity [l]	Weight empty [kg]	Article No.
2	With	7.2	325	75	3571.40.10
2	Without	7.2	325	70	3571.40.00
Operating set consisting of four barrels and two connecting sets					0170.30.35
Retrofit set for pressure increase					0170.29.87

Product overview

Lipator-P-RM grease separator for partial disposal made of polyethylene for free standing installation



ACO Product advantages

- Compact footprint dimensions for small applications
- Easy handling and insertion
- Self-explaining and illuminated control box
- Adjustable timer clock for flexible grease extraction

Product information

- Grease separator plant according to EN 1825 for free-standing installation in frost proof rooms
- Manufactured of welded polyethylene
- Inlet and outlet for plastic pipe connection
- With extraction valves DN 50 for grease and sludge extraction
- With heating rod and timer clock for homogenizing of grease
- Electric connection: 230 V, 50/60 Hz

Dimensional drawing

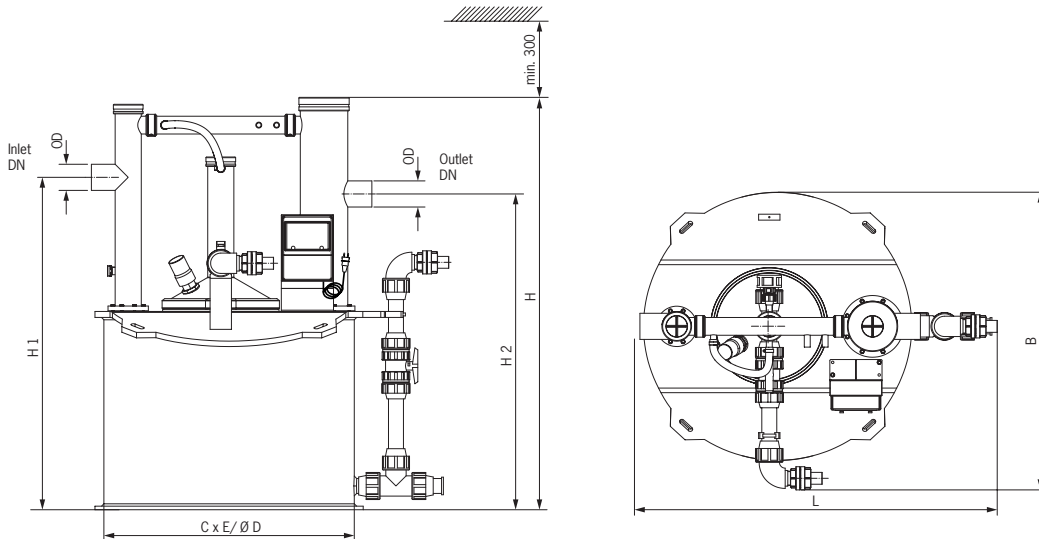

Table of dimensions

NS	Inlet/ outlet OD [mm]	Dimensions [mm]						Largest single component Ø D x H [mm]	Article No.
		L	B	Ø D	H	H1	H2		
4	110	1500	1270	1055	1830	1400	1330	Ø 1270 x 860	3574.40.10
10	160	1990	1530	1525	2210	1800	1730	Ø 1660 x 660	3580.40.10
20	200	2240	1910	1775	2320	1900	1830	Ø 1920 x 700	3590.40.10
25	200	2240	1910	1775	2420	2000	1930	Ø 1920 x 700	3595.40.10

Lipator-S-RM grease separator for partial disposal made of stainless steel for free standing installation



ACO Product advantages

- Compact footprint dimensions for small applications
- Easy handling and insertion
- Self-explaining and illuminated control box
- Adjustable timer clock for flexible grease extraction

Product information

- Grease separator plant according to EN 1825 for free-standing installation in frost proof rooms
- Manufactured of stainless steel, material grade 316
- Inlet and outlet for plastic pipe connection
- With extraction valves DN 50 for grease and sludge extraction
- With heating rod and timer clock for homogenizing of grease
- Electric connection:
 - 230 V, 50/60 Hz

Dimensional drawing

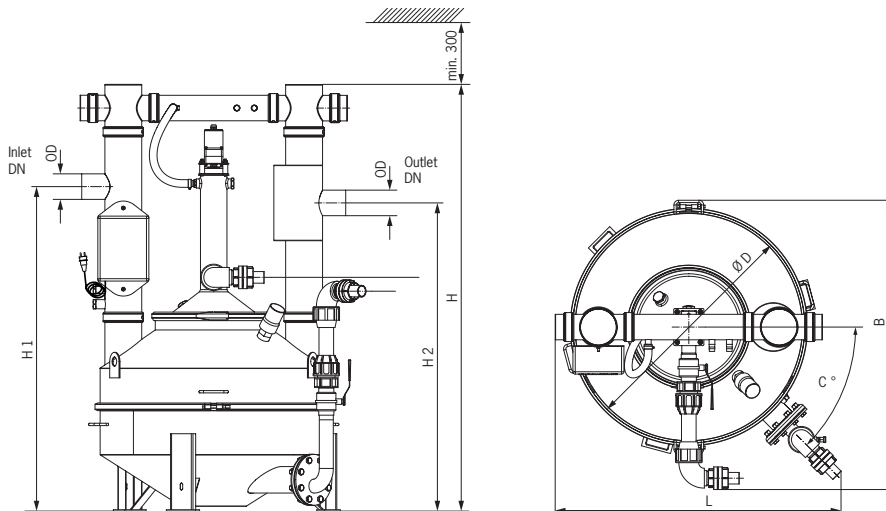

Table of dimensions

NS	Inlet/outlet OD [mm]	Dimensions							Largest single component Ø D x H [mm]	Article No. with agitating device	Article No. without agitating device
		L [mm]	B [mm]	C [°]	Ø D [mm]	H [mm]	H1 [mm]	H2 [mm]			
2	110	1170	970	115	640	1700	1300	1230	Ø 750 x 880	7672.40.50	7672.40.10
4	110	1240	1300	45	980	1850	1400	1330	Ø 980 x 450	7674.40.50	7674.40.10
10	160	1710	1670	45	1500	2200	1800	1730	Ø 1500 x 650	7680.40.50	7680.40.10
20	200	1950	1880	45	1750	2320	1900	1830	Ø 1750 x 780	7690.45.50	7690.40.10
25	200	1950	1880	45	1750	2420	2000	1930	Ø 1750 x 780	7695.40.50	7695.40.10

Product overview

Lipator-P-RA grease separator for partial disposal made of polyethylene for free standing installation



ACO Product advantages

- Compact footprint dimensions for small applications
- Easy handling and insertion
- Self-explaining and illuminated control box
- Adjustable timer clock for flexible grease extraction
- Automated grease and sludge extraction

Product information

- Grease separator plant according to EN 1825 for free-standing installation in frost proof rooms
- Manufactured of welded polyethylene
- Inlet and outlet for plastic pipe connection
- With automated grease and sludge extraction
- With hoses and four tanks 60 liters for grease and sludge collection
- With agitating device and scraper
- With heating rod and timer clock for homogenizing of grease
- Electric connection: 230 V, 50/60 Hz

Dimensional drawing

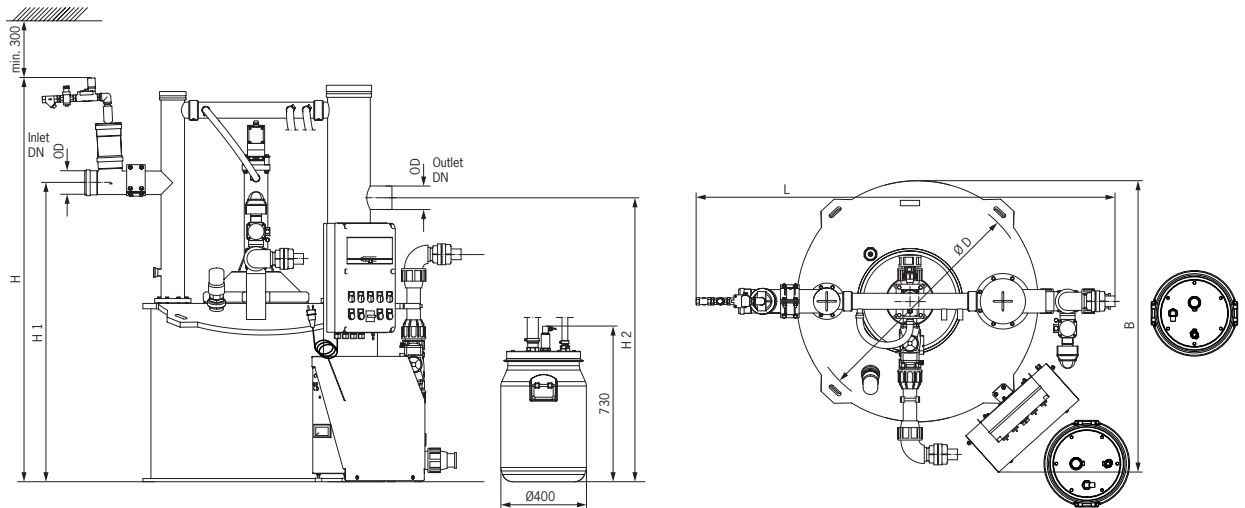

Table of dimensions

NS	Inlet/outlet OD [mm]	Dimensions [mm]						Largest single component Ø D x H [mm]	Article No.
		L	B	Ø D	H	H1	H2		
4	110	1950	1350	1060	1850	1400	1330	Ø 1270 x 860	3574.70.10
10	160	2500	1850	1530	2320	1800	1730	Ø 1660 x 660	3580.70.10
20	200	2750	2050	1780	2560	1900	1830	Ø 1920 x 700	3590.70.10
25	200	2750	2050	1780	2660	2000	1930	Ø 1920 x 700	3595.70.10

Lipator-S-RA grease separator for partial disposal made of stainless steel for free standing installation



ACO Product advantages

- Compact footprint dimensions for small applications
- Easy handling and insertion
- Self-explaining and illuminated control box
- Adjustable timer clock for flexible grease extraction
- Automated grease and sludge extraction

Product information

- Grease separator plant according to EN 1825 for free-standing installation in frost proof rooms
- Manufactured of stainless steel, material grade 316
- Inlet and outlet for plastic pipe connection
- With automated grease and sludge extraction
- With hoses and four tanks 60 liters for grease and sludge collection
- With agitating device and scraper
- With heating rod and timer clock for homogenizing of grease
- Electric connection: 230 V, 50/60 Hz

Dimensional drawing

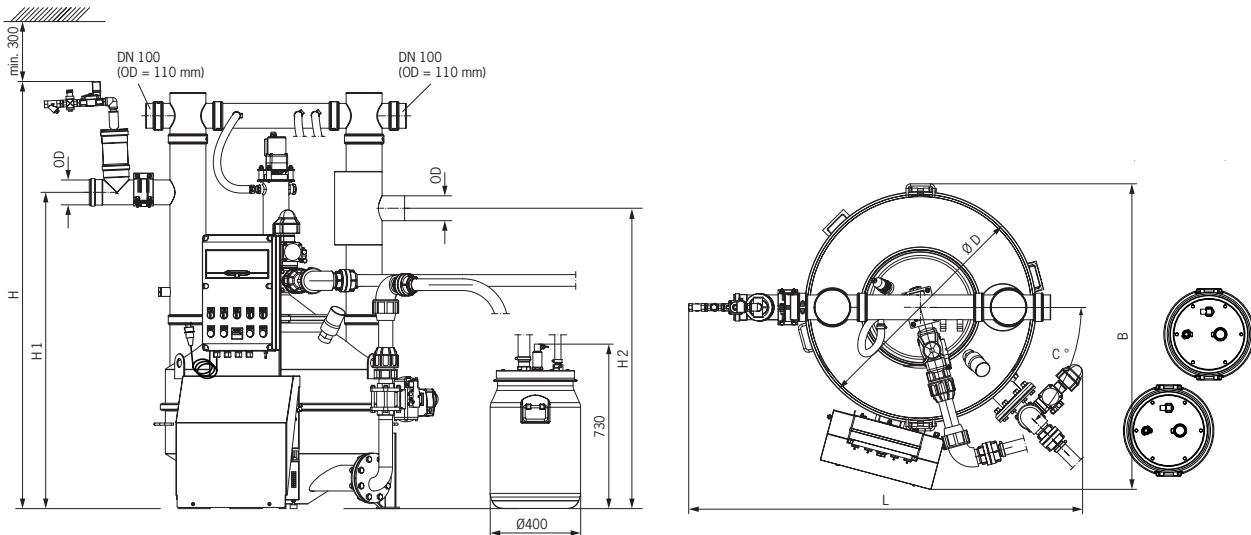







Table of dimensions







NS	Inlet/outlet OD [mm]	Dimensions							Largest single component Ø D x H [mm]	Article No.
		L [mm]	B [mm]	C [°]	Ø D [mm]	H [mm]	H1 [mm]	H2 [mm]		
2	110	1170	970	115	640	1700	1300	1230	Ø 750 x 880	7672.70.10
4	110	1240	1300	45	980	1850	1400	1330	Ø 980 x 450	7674.70.10
10	160	1710	1670	45	1500	2200	1800	1730	Ø 1500 x 650	7680.70.10
20	200	1950	1880	45	1750	2320	1900	1830	Ø 1750 x 780	7690.70.10
25	200	1950	1880	45	1750	2420	2000	1930	Ø 1750 x 780	7695.70.10







Supplementary components

	Designation	To fit	Description	Article no.
	Grease level sensor	<ul style="list-style-type: none"> ■ LipuJet-P <ul style="list-style-type: none"> □ Oval NS 1 – 10 □ Round NS 2 – 20 ■ LipuJet-S <ul style="list-style-type: none"> □ Oval NS 1 – 10 □ Round NS 2 – 20 	<ul style="list-style-type: none"> ■ For electronic measurement of grease layer ■ Suitable for liquid and/or congealing grease ■ Measuring device with cable, length: 3 m ■ With two isolated change-over contacts to display full warning (80%) and advance warning of fill level (50%) ■ With visual display of fill level ■ With heated probe rod to increase operating reliability ■ Operating voltage: 230 VAC/5 VA ■ Max. consumption: 12 W 	3300.11.50
	Signalling unit with GSM module	<ul style="list-style-type: none"> ■ Grease separators extension stage 3 ■ Measuring equipment for grease layer thickness 	<ul style="list-style-type: none"> ■ Mains-independent ■ Visible and audible alarm signals ■ 6 digital & 2 analogue freely configurable inputs ■ 1 alarm output 12 V ■ Includes GSM antenna (2.5 m cable) ■ Relaying alarms to mobile phones by SMS ■ For mounting outside the ex area ■ Housing: 155 x 180 x 103 mm ■ Slot for standard SIM card ■ Protection type: IP 54 (with mounted antenna plug IP 44) ■ Operating voltage: 230 V/AC 50/60 Hz 	0150.46.94
	Heating rod	<ul style="list-style-type: none"> ■ Grease separators 	<ul style="list-style-type: none"> ■ To liquefy grease layer ■ Incl. control ■ Electrical connection <ul style="list-style-type: none"> □ 400 V/50 Hz/16 A/6.0 kW 	7300.01.00
	Filling device	<ul style="list-style-type: none"> ■ LipuJet-P-OB, -OD, -RB, -RD grease separators 	<ul style="list-style-type: none"> ■ Free outlet according to DIN 1988 Part 4 ■ For connection to drinking water supply ■ With ball valve R 3/4" ■ With pressure relief valve 	3300.11.22
		<ul style="list-style-type: none"> ■ LipuJet-S-OB, -OD, -RB, -RD grease separators 	<ul style="list-style-type: none"> ■ Free outlet according to DIN 1988 Part 4 ■ For connection to drinking water supply ■ With ball valve R 3/4" ■ With pressure relief valve 	7602.00.25
		<ul style="list-style-type: none"> ■ LipuJet-P-SB, -SD 	<ul style="list-style-type: none"> ■ Free outlet according to DIN 1988 Part 4 ■ For connection to drinking water supply ■ With ball valve R 3/4" ■ With pressure relief valve 	0153.06.76

	Designation	To fit	Description	Article no.
	Remote control	<ul style="list-style-type: none"> ■ LipuJet-P-OA/RA/OAE/RAE grease separators 	<ul style="list-style-type: none"> ■ For inside assembly or mounting in connection boxes ■ Control line without local protective conductor <ul style="list-style-type: none"> □ Up to 50 m: 7 x 1.0 mm² □ 50 – 200 m: 7 x 1.5 mm² ■ IP 54 protection type ■ Weight: 1 kg 	0150.59.89
	Connection box	<ul style="list-style-type: none"> ■ Grease separators ■ Starch separators 	<ul style="list-style-type: none"> ■ For disposal connection and remote control ■ Made of stainless steel, material grade 304 ■ Fixing: "on-wall" ■ Dimensions (width x height x depth): 500 x 500 x 160 mm 	7601.80.20
	In-wall frame	<ul style="list-style-type: none"> ■ Connection box <ul style="list-style-type: none"> □ 7601.80.22 	<ul style="list-style-type: none"> ■ Made of stainless steel, material grade 304 ■ Dimensions (width x height x depth): 421 x 381 x 25 mm 	7601.80.21
	Inspection window	<ul style="list-style-type: none"> ■ LipuJet-P-OB, -OD, -R, -RD grease separators 	<ul style="list-style-type: none"> ■ Nominal width: ND 200 ■ With wiper ■ Weight: 5 kg 	3300.11.10
	Inspection window	<ul style="list-style-type: none"> ■ LipuJet-S-OB, -OD, -R, -RD grease separators 	<ul style="list-style-type: none"> ■ Nominal width: ND 200 ■ With wiper ■ Weight: 5 kg 	7602.00.26

Supplementary components

	Designation	To fit	Description	Article no.
	Sampling pot ND 100	<ul style="list-style-type: none"> ■ Eco-Jet/ Hydrojet grease separators <ul style="list-style-type: none"> <input type="checkbox"/> NS 1 – 4 ■ Lipator-P-RM/ Lipator-P-RA <ul style="list-style-type: none"> <input type="checkbox"/> NS 1 – 4 	<ul style="list-style-type: none"> ■ For installation in horizontal pipelines ND 100 downstream of separator plants ■ Material: PE ■ Round shape with <ul style="list-style-type: none"> <input type="checkbox"/> Coupling socket seal (material SBR) on inlet and spigot on outlet <input type="checkbox"/> Odour-proof maintenance opening ND 450 ■ Weight: 7 kg 	3300.09.11
	Sampling pot ND 150	<ul style="list-style-type: none"> ■ Eco-Jet/ Hydrojet grease separators <ul style="list-style-type: none"> <input type="checkbox"/> NS 5.5 – 10 ■ Lipator-P-RM/ Lipator-P-RA <ul style="list-style-type: none"> <input type="checkbox"/> NS 7 – 10 	<ul style="list-style-type: none"> ■ For installation in horizontal pipelines ND 150 downstream of separator plants ■ Material: PE ■ Round shape with <ul style="list-style-type: none"> <input type="checkbox"/> Coupling socket seal (material SBR) on inlet and spigot on outlet <input type="checkbox"/> Odour-proof maintenance opening ND 450 ■ Weight: 7 kg 	3300.09.21
	Sampling pot ND 200	<ul style="list-style-type: none"> ■ Eco-Jet/ Hydrojet grease separators <ul style="list-style-type: none"> <input type="checkbox"/> NS 15 – 25 ■ Lipator-P-RM/ Lipator-P-RA <ul style="list-style-type: none"> <input type="checkbox"/> NS 15 – 25 	<ul style="list-style-type: none"> ■ For installation in horizontal pipelines ND 200 downstream of separator plants ■ Material: PE ■ Round shape with <ul style="list-style-type: none"> <input type="checkbox"/> Coupling socket seal (material SBR) on inlet and spigot on outlet <input type="checkbox"/> Odour-proof maintenance opening ND 450 ■ Weight: 7 kg 	3300.09.31
	Sampling pot ND 100	<ul style="list-style-type: none"> ■ Eco-Jet/ Hydrojet grease separators <ul style="list-style-type: none"> <input type="checkbox"/> NS 1 – 4 ■ Lipator-P-RM/ Lipator-P-RA <ul style="list-style-type: none"> <input type="checkbox"/> NS 1 – 4 	<ul style="list-style-type: none"> ■ For installation in vertical pipelines ND 100 downstream of separator plants ■ Material: PE ■ Round shape with <ul style="list-style-type: none"> <input type="checkbox"/> Coupling socket seal (material SBR) on inlet and spigot on outlet <input type="checkbox"/> Odour-proof maintenance opening ND 450 ■ Weight: 7 kg 	3300.10.11
	Sampling pot ND 150	<ul style="list-style-type: none"> ■ Eco-Jet/ Hydrojet grease separators <ul style="list-style-type: none"> <input type="checkbox"/> NS 5.5 – 10 ■ Lipator-P-RM/ Lipator-P-RA <ul style="list-style-type: none"> <input type="checkbox"/> NS 7 – 10 	<ul style="list-style-type: none"> ■ For installation in vertical pipelines ND 150 downstream of separator plants ■ Material: PE ■ Round shape with <ul style="list-style-type: none"> <input type="checkbox"/> Coupling socket seal (material SBR) on inlet and spigot on outlet <input type="checkbox"/> Odour-proof maintenance opening ND 450 ■ Weight: 7 kg 	3300.10.21
	Sampling pot ND 200	<ul style="list-style-type: none"> ■ Eco-Jet/ Hydrojet grease separators <ul style="list-style-type: none"> <input type="checkbox"/> NS 15 – 25 ■ Lipator-P-RM/ Lipator-P-RA <ul style="list-style-type: none"> <input type="checkbox"/> NS 15 – 25 	<ul style="list-style-type: none"> ■ For installation in vertical pipelines ND 200 downstream of separator plants ■ Material: PE ■ Round shape with <ul style="list-style-type: none"> <input type="checkbox"/> Coupling socket seal (material SBR) on inlet and spigot on outlet <input type="checkbox"/> Odour-proof maintenance opening ND 450 ■ Weight: 7 kg 	3300.10.31

	Designation	To fit	Description	Article no.
	Sampling pot ND 100	<ul style="list-style-type: none"> ■ Lipurex/Lipurat/ Lipator-P-RM/ Lipator-P-RA grease separators □ NS 1 – 4 	<ul style="list-style-type: none"> ■ Made of stainless steel, material grade 316 ■ Round shape ■ Gradient: 70 mm ■ For installation in horizontal pipelines ND 100 downstream of separator plants ■ With pipe connector and claw ■ Connections according to EN 877 ■ Weight: 13 kg 	7300.09.10
	Sampling pot ND 150	<ul style="list-style-type: none"> ■ Lipurex/Lipurat/ Lipator-P-RM/ Lipator-P-RA grease separators □ NS 5.5 – 10 	<ul style="list-style-type: none"> ■ Made of stainless steel, material grade 316 ■ Round shape ■ Gradient: 70 mm ■ For installation in horizontal pipelines ND 150 downstream of separator plants ■ With pipe connector and claw ■ Connections according to EN 877 ■ Weight: 14 kg 	7300.09.20
	Sampling pot ND 200	<ul style="list-style-type: none"> ■ Lipurex/Lipurat/ Lipator-P-RM/ Lipator-P-RA grease separators □ NS 15 – 20 	<ul style="list-style-type: none"> ■ Round shape ■ Gradient: 70 mm ■ For installation in horizontal pipelines ND 200 downstream of separator plants ■ With pipe connector and claw ■ Connections according to EN 877 ■ Weight: 15 kg 	7300.09.30
	Sampling pot ND 100	<ul style="list-style-type: none"> ■ Lipurex/Lipurat/ Lipator-P-RM/ Lipator-P-RA grease separators □ NS 1 – 4 ■ Fapurat starch separators □ NS 0.5 – 1 	<ul style="list-style-type: none"> ■ Made of stainless steel, material grade 316 ■ Round shape ■ For installation in vertical pipelines ND 100 downstream of separator plants ■ With pipe connector and claw ■ Connections according to EN 877 ■ Weight: 13 kg 	7300.10.20
	Sampling pot ND 150	<ul style="list-style-type: none"> ■ Lipurex/Lipurat/ Lipator-P-RM/ Lipator-P-RA grease separators □ NS 5.5 – 10 	<ul style="list-style-type: none"> ■ Made of stainless steel, material grade 316 ■ Round shape ■ For installation in vertical pipelines ND 150 downstream of separator plants ■ With pipe connector and claw ■ Connections according to EN 877 ■ Weight: 14 kg 	7300.15.20
	Sampling pot ND 200	<ul style="list-style-type: none"> ■ Lipurex/Lipurat/ Lipator-P-RM/ Lipator-P-RA grease separators □ NS 15 – 20 	<ul style="list-style-type: none"> ■ Made of stainless steel, material grade 316 ■ Round shape ■ For installation in vertical pipelines ND 200 downstream of separator plants ■ With pipe connector and claw ■ Connections according to EN 877 ■ Weight: 15 kg 	7300.16.20

Supplementary components

	Designation	To fit	Description	Article no.
	Inlet valve ND 50	<ul style="list-style-type: none"> ■ Polyethylene grease separator LipuMobil-P, 0.3 	<ul style="list-style-type: none"> ■ Made of PVC ■ 50 mm push socket on both sides with lip seal ■ Overall dimensions: 91 x 250 mm ■ Weight: 2.1 kg 	0175.18.33
	Inlet valve ND 100	<ul style="list-style-type: none"> ■ Polyethylene grease separators LipuMobil-P, 0.5 	<ul style="list-style-type: none"> ■ Made of PVC ■ 110 mm push socket on both sides with lip seal ■ Overall dimensions: 176 x 330 mm (L x H) ■ Weight: 2.75 kg 	0175.13.84
	Inlet valve ND 150	<ul style="list-style-type: none"> ■ Polyethylene grease separators 	<ul style="list-style-type: none"> ■ Made of PVC ■ 160 mm push socket on both sides with lip seal ■ Overall dimensions: 226 x 510 mm (L x H) ■ Weight: 6.5 kg 	0175.13.85
	Inlet valve ND 200	<ul style="list-style-type: none"> ■ Polyethylene grease separators 	<ul style="list-style-type: none"> ■ Made of PVC ■ 50 mm push socket on both sides with lip seal ■ Overall dimensions: 290 x 740 mm ■ Weight: 9.5 kg 	0170.20.83
	Stop valve ND 100	<ul style="list-style-type: none"> ■ Grease separators for free-standing installation ■ Starch separators for free-standing installation 	<ul style="list-style-type: none"> ■ Made of cast iron ■ Valve plate, spindle made of stainless steel, material grade 304 ■ Length (L): 50 mm ■ Spindle travel (H1 – H2): 365 – 465 mm ■ Hand wheel diameter: 200 mm 	7602.00.12
	Stop valve ND 150	<ul style="list-style-type: none"> ■ Grease separators for free-standing installation ■ Starch separators for free-standing installation 	<ul style="list-style-type: none"> ■ Made of cast iron ■ Valve plate, spindle made of stainless steel, material grade 304 ■ Length (L): 60 mm ■ Spindle travel (H1 – H2): 478 – 639 mm ■ Hand wheel diameter: 200 mm 	7604.00.12
	Stop valve ND 200	<ul style="list-style-type: none"> ■ Grease separators for free-standing installation ■ Starch separators for free-standing installation 	<ul style="list-style-type: none"> ■ Made of cast iron ■ Valve plate, spindle made of stainless steel, material grade 304 ■ Length (L): 60 mm ■ Spindle travel (H1 – H2): 542 – 743 mm ■ Hand wheel diameter: 250 mm 	7610.00.12

	Designation	To fit	Description	Article no.
	Flange connection ND 100	<ul style="list-style-type: none"> ■ Stop valve □ 7602.00.12 □ 7604.00.12 □ 7610.00.12 	<ul style="list-style-type: none"> ■ Made of stainless steel, material grade 304 ■ Sealing: NBR ■ Length (L): 75 mm 	7602.00.13
	Flange connection ND 150	<ul style="list-style-type: none"> ■ Stop valve □ 7602.00.12 □ 7604.00.12 □ 7610.00.12 	<ul style="list-style-type: none"> ■ Made of stainless steel, material grade 304 ■ Sealing: NBR ■ Length (L): 75 mm 	7604.00.13
	Flange connection ND 200	<ul style="list-style-type: none"> ■ Stop valve □ 7602.00.12 □ 7604.00.12 □ 7610.00.12 	<ul style="list-style-type: none"> ■ Made of stainless steel, material grade 304 ■ Sealing: NBR ■ Length (L): 120 mm 	7610.00.13
		<ul style="list-style-type: none"> ■ DN 100 ■ DN 150 ■ DN 200 	<ul style="list-style-type: none"> ■ Coarse trap ■ PE with cone and penstock ■ Housing 480 mm ■ Drainage connection DN 100 (OD 110 mm) with stop valve ■ Ventilation connection DN 20 for venting the on-site collecting tank ■ Cover with clamping ring ■ Odourproof ■ Tabs for ceiling fixing on site 	<p>0170.31.62</p> <p>0170.31.63</p> <p>0170.31.64</p>
		<ul style="list-style-type: none"> ■ Lipator 	<ul style="list-style-type: none"> ■ 2 drums □ Complete with hoses □ Capacity 60 liters □ With Plexiglas cover □ With clamping ring and hose connection DN 25 and DN 40 □ 2 hoses DN 25 (length 2,500 mm) and 2 hoses DN 40 (length 1,500 mm) ■ 2 replacement drums 60 liters with cover and clamping ring only 	0170.30.35

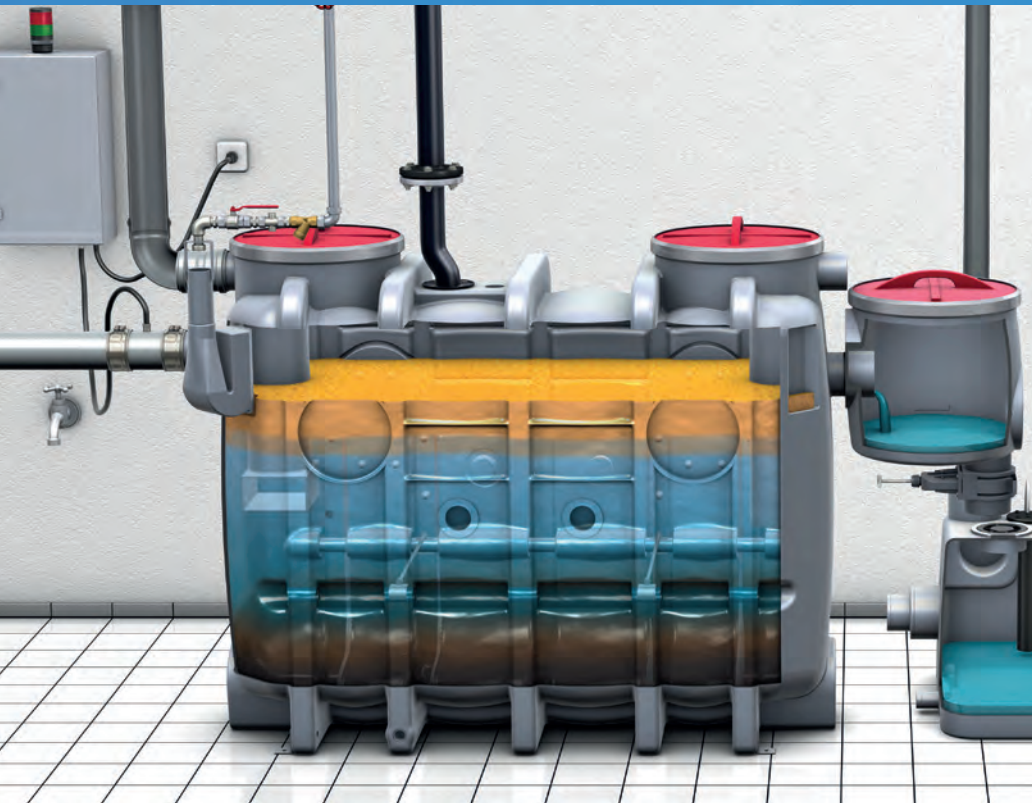

Process optimisation

of ACO grease separator plants

ACO LipuFloc dosing station **Page 76**

The high level of organic pollution by oils and fats in waste water from kitchens requires the installation of a grease separator plant. In the separators, the waste water is treated solely by gravity, which means only freely separable oils, fats and sediments are retained. Emulsified and dissolved components will pass through the separator virtually unimpeded. This can mean exceeding the limit values where more stringent requirements on the levels of non-volatile lipophilic substances apply. As this parameter is high on the agenda of the authorities in many cities (e.g. Frankfurt), the focus is increasingly on adding treatment methods which go further, downstream of the grease separator plants.

ACO odour neutraliser **Page 77**

Incorrectly designed or damaged ventilation lines can cause unpleasant smells to escape from grease separator plants. An ACO odour neutraliser can prevent such smells from spreading, with the odour neutralising agent being dosed under timer control.

ACO LipuFloc dosing station



Product benefits

- Compact, space-saving shape
- Ready to connect, rapid to install
- Low cost of maintenance
- Rapid top up of active agent (flocculant)
- Suitable for waste water containing grease or fat, for ACO grease separators up to NS 25
- Functions fully automatically with effective adjustment to kitchen's pattern of working

Product description

- Chemical-physical waste water treatment to reduce concentrations of fats and oils in ACO grease separator gullies
- Energy-saving and user-friendly automatic operation to treat waste water from restaurant kitchens
- Stainless steel cabinet and lockable door with touch panel
 - Lockable door for storage of flocculant
 - Height-adjustable feet with rubber pads
 - 230 V/50 – 60 Hz mains socket (freely accessible on rear wall to be used in-situ)
- Dosing pump
- Circulation pump
- Controls
 - In-situ power supply 230 V/50 – 60 Hz/2 A
 - IP 54 protection type
 - Isolated group alarm and operation signal
- Flocculant – 125 kg
- Touch panel
 - 7" colour touch panel
 - Process display
 - Inspection and setting of parameters

Essential conditions for marketing and sale of LipuFloc are a basic product training of sales team and service technician and a network of local service partners.

Free-standing installation

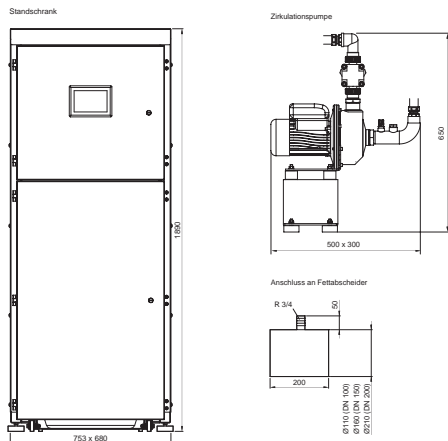

Below ground installation

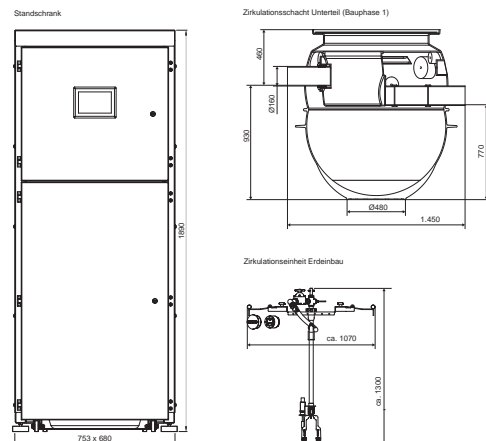

Dosing station/accessories	To fit	Weight [kg]	Article no.
ACO LipuFloc	ACO grease separators for free-standing installation with control	320	Article number/price on demand
	ACO grease separators for free-standing installation without control	320	
	ACO grease separators for below ground installation	380	
Container for flocculant "ACO PW Grease Flocculant"	ACO LipuFloc	125	

ACO odour neutraliser



Product benefits

- Effective neutralisation of unpleasant smells
- Simple, uncomplicated application
- Retrofittable at any time
- Independent of extension stages
- Dosing quantity and time can be adjusted to the individual catering establishment
- For universal use

Product description

- System for neutralising unpleasant smells
- Possible uses: grease separators, lifting plants for waste water containing grease or fat
- The odour neutraliser consists of:
 - Switchgear
 - Time-controlled dosing pump
 - Odour neutralising agent

Dimensions

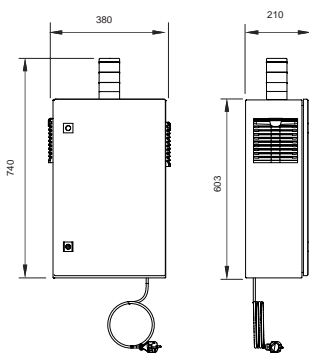

Designation	To fit	Weight [kg]	Article no.
ACO odour neutraliser	■ Grease separators	25	7980.80.00
Refilling liquid citral 9 liters	■ Odour neutraliser	10	0155.25.67

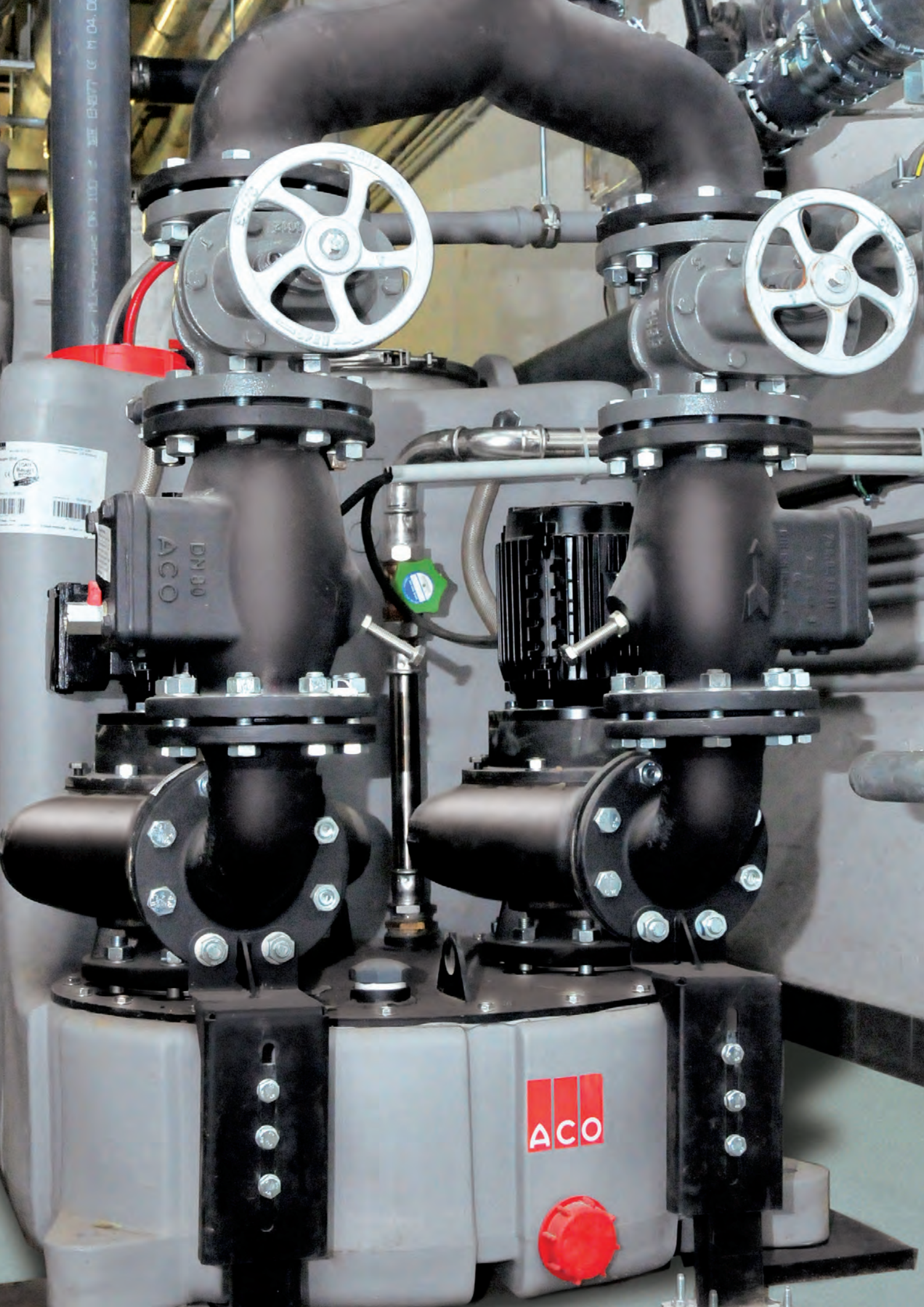

ACO
DN100

ACO

Barcode and technical specifications on a white container label.

Vertical text on a black pipe: *PLK-Gruppe DN 100 - SEE B&BTT G M 04. D.*

Lifting plants

Grease separators whose static water level is below the backflow level must be connected to the waste water system via a lifting plant on the outlet side. In doing so, the discharge pressure line must be pulled above the backflow level by means of a backflow loop. To increase operating reliability, lifting plants with two pumps must always be used.

**Lifting plants for installation downstream of grease separators
for free-standing installation**

	Designation	To fit	Description	Article no.
	Muli-Mini duo	<ul style="list-style-type: none"> ■ For separators up to NS 4 	<ul style="list-style-type: none"> ■ Polyethylene tank ■ Usable volume 55 – 130 litres ■ Two grey water submerged pumps IP 68 ■ Operating voltage 230 or 400 volts ■ Pneumatic level switching ■ Discharge pressure line connection Rp 2" ■ Inlet socket ND 100 ■ Ventilation connection ND 70 ■ Container dimensions (L x W x H): 600 x 815 x 710 mm ■ Empty weight: <ul style="list-style-type: none"> □ 66 kg (Muli-Mini DDP 1.1) and □ 74 kg (Muli Mini DDP 1.2) <p>DDP 1.1 (P2 = 0.55 kW) DDP 1.2 (P2 = 1.1 kW) DWP 1.1 (P2 = 0.55 kW) DWP 1.2 (P2 = 1.1 kW)</p> <p>Note: To increase operating reliability, if this product is used we recommend equipping the plant with air bubble injection downstream of grease separators.</p>	<p>1206.00.01 1206.00.02 1206.00.03 1206.00.04</p>
	Muli-Star DDP	<ul style="list-style-type: none"> ■ For separators up to NS 15 	<ul style="list-style-type: none"> ■ Polyethylene tank ■ Usable volume 65 – 185 litres ■ Two pumping sets IP 68 ■ Operating voltage 400 volts ■ Pneumatic level switching ■ Pressure connection for pressure tubing Ø 108 – 114.3 mm ■ Inlet socket: ND 100/150/200 ■ Ventilation socket ND 70/100 ■ Container dimensions (L x W x H): 920 mm x 770 mm x 690 mm ■ Empty weight: 104 – 128 kg <p>DDP 1.1 (P2 = 1.5 kW) DDP 1.2 (P2 = 3.0 kW) DDP 2.1 (P2 = 1.5 kW) DDP 2.2 (P2 = 3.0 kW)</p> <p>Note: To increase operating reliability, if this product is used we recommend equipping the plant with air bubble injection downstream of grease separators.</p>	<p>1202.00.01 1202.00.02 1202.00.04 1202.00.05</p>

	Designation	To fit	Description	Article no.
	Multi-Pro PE K duo with air bubble injection	<ul style="list-style-type: none"> ■ For separators up to NS 20 	<ul style="list-style-type: none"> ■ Polyethylene tank ■ Usable volume 240 – 330 litres ■ Two pumping sets IP 68 ■ Operating voltage 400 volts ■ Pneumatic level switching incl. air bubble injection for reliable function ■ Pressure connection for pressure tubing Ø 108 – 114.3 mm ■ Inlet socket ND 150 ■ Ventilation socket ND 100 – container dimensions (L x W x H): 1500 mm x 780 mm x 1035 mm ■ Empty weight: 295 – 495 kg <p>K-15 (P2 = 1.5 kW) K-22 (P2 = 2.2 kW) K-30 (P2 = 3.0 kW) K-55 (P2 = 5.5 kW) K-75 (P2 = 7.5 kW)</p>	<p>0175.13.17 0175.13.18 0175.13.19 0175.13.20 0175.13.21</p>

Supplementary components

	Designation	To fit	Description	Article no.
	Air bubble injection	<ul style="list-style-type: none"> ■ Multi-Mini duo ■ Multi-Star DDP 	<ul style="list-style-type: none"> ■ For retro-fitting on Multi-Mini and Multi-Star DDP wastewater lifting plants ■ With min compressor and connectors ■ To increase operational safety ■ To deal with generation of floating layers (wastewater containing grease) 	0154.81.27

ACO lifting plants for grease separators NS 15 and 20



ACO Product advantages

- Large usable tank volume
- Various inlet heights
- Good operational safety thanks to pilot tube and air bubble injection
- Suitable for waste water containing grease or fat
- Can be extended into a parallel plant
- Energy-saving channel impeller
- Adjusted for door width of: 780 mm

Muli Pro-PE K-15 parallel lifting plant for installation downstream of grease separators

- Two polyethylene tanks with a drain plug or connection for a manual membrane pump R 1½", fixing kit for buoyancy safety
- Total volume: 1040 litres
- Operating volume depending on the inlet height selected, various inlets Ø 160 mm at various positions
- Two inspection openings, clear width 320 mm, ventilation line Ø 110 mm, discharge pressure line connection for pressure

tubing made of plastic or SML with external diameter from 108 to 114.3 mm

- Two pumps 400 V, 50 Hz, IP 68 protection type (for performance data, see diagram on next page), with air bubble injection for maximum operational safety
- Switching device with warning device IP 54 protection type with digital display, for alternate operation of the two pumps, with 1.5 metre cable and CEE plug 16 A (from 4 kW, 32 A), with isolated contact for group alarm to central technical supervision, with 7 metres of cabling between lifting plant and switching device

Dimensions

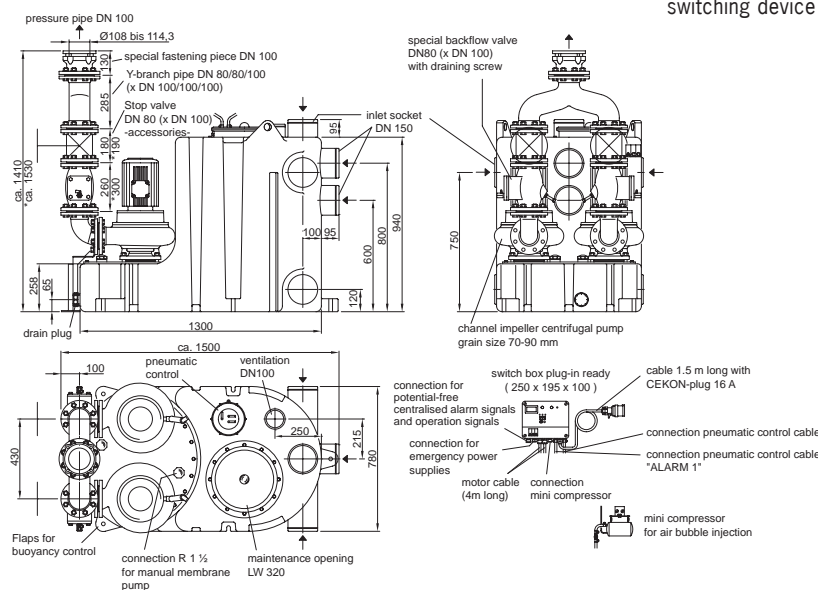

Type	Motor capacity (P1) [kW]	Weight [kg]	Article. no.
K-15	1.5	315	0175.13.23
K-22	2.2	325	0175.13.24
K-30	3.0	42	0175.13.25
K-55	5.5	465	0175.13.26
K-75	7.5	510	0175.13.27

**ACO lifting plants for grease separators
NS 25 and 30**



- ACO Product advantages**
- Tank can be configured individually to customer requirements
 - Good operational safety and reliability
 - Pump with adaptive impeller reduces blockages in operation
 - No need to ventilate the pump, as it is installed horizontally
 - Large usable volume (standard up to 1100 l)
 - Energy-saving channel impeller
 - Selectable inlet height (375 – 1325 mm depending on model)

**Muli Pro-PE K XL lifting plant
for installation downstream of grease separators**

- Polyethylene tank with fixing kit for in-situ anchorage to prevent upwelling
- Inlet connection Ø 200 mm (selectable position), ventilation connection Ø 110 mm for connecting pressure tubing from 114.3 mm
- Flexible container dimensions according to the table below, corresponding operating volume
- Two pumps 400 V, 50 Hz, IP 68 protection type, both pumps with piping and with two stop valves each
- Pneumatic switching system with air bubble injection for maximum operational safety
- Multi Control switching device IP 54 protection type with digital display for alternate operation of the two pumps, with 1.5 metre cable and CEE plug 16 A, wired and ready to plug in, with isolated contact for group alarm and operating signal, with 10 metres of cabling between switching device and lifting plant

Dimensions

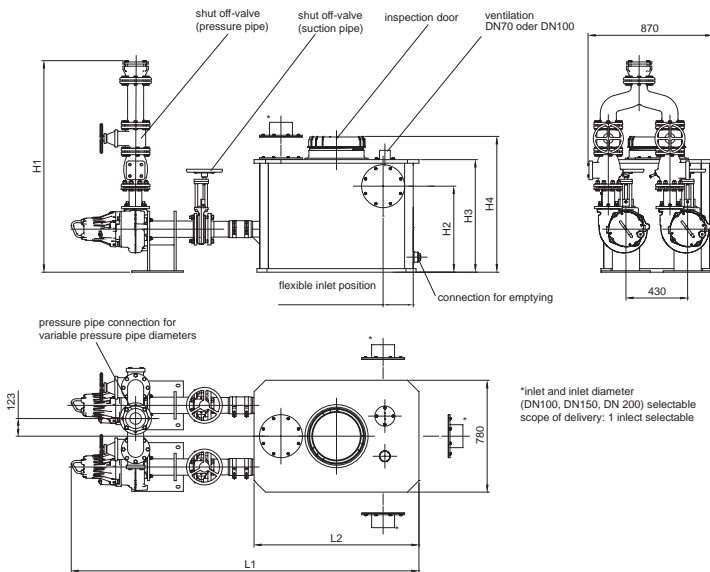

Type	Flexible dimensions						Article no.
	L1 [mm]	L2 [mm]	H1 [mm]	H2 [mm]	H3 [mm]	H4 [mm]	
Muli Pro-PE K XL	2260 – 3110	1150 – 2000	Approx. 1475	375 – 1325	560 – 1510	722 – 1672	Article number/price on demand

The ACO service chain

Each project is different, bringing its own demands and challenges with it. As well as our products we can offer you our expertise and our services, in order to develop a customised solution together with you – from planning to its maintenance once in service.



train:
information and additional training

In the ACO Academy we share all the expertise within the worldwide ACO Group with architects, designers, processors and resellers, to whom quality matters. We invite you to benefit from this.

design:
planning and optimisation

The tendering and planning of drainage solutions includes many variations. But which design will actually deliver the most profitable and technically safest solution? We can help you find the right answers.

support:
construction advice and assistance

So that there are no unpleasant surprises between the planning and the implementation of a drainage solution, we can advise and support you with your project on your construction site.

care:
inspection and servicing

ACO products are designed and manufactured to last a long time. Our after sales service ensures that ACO continues to meet your stringent quality requirements for many years to come.

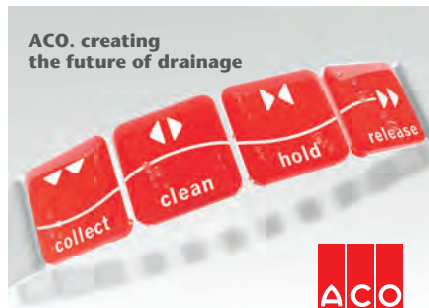

Every product from ACO Haustechnik integrates into the ACO system chain

Drainage

- Floor drainage
- Bath drainage
- Backflow systems
- Roof drainage
- Parking deck drainage
- Balcony and terrace drainage
- Pipe systems

Separation

- Grease separators
- Starch separators
- Light liquid separators
- Process technology

Pumping

- Lifting plants
- Pumping stations

ACO Passavant GmbH

Im Gewerbepark 11c
36457 Stadtlengsfeld, Germany
Tel. +49 (0) 36965 819-0
Fax +49 (0) 36965 819-361
www.aco-haustechnik.de