



ACO. The Future of Drainage...

LIPUMOBILIN –P 0.3

Testing and Certification

The LipuMobilin –P 0.3 separator is tested and rated at the TUV LGA institute in Germany according to EN-1825-1. While the allowable grease residue at outlet is 25mg/l as per EN1285, LipuMobilin has recorded extraordinary results of 5mg/l during the tests.

Product Benefits

- Easy to install
- Low Weight
- Compact Dimensions
- Odourproof cover
- Easy to clean

Industry

- Restaurants
- Kitchens
- Fast-food Stalls
- Mobile food courts

- With integrated sludge trap
- Free-standing indoor areas
- Polypropylene



ACO Systems and Solutions Pvt. Ltd.

No: 19/2, Fathima Towers
Rhenius Street, Langford Town
Bangalore 560025

www.aco.in

E-mail: customercare@acosystems.in



LIPUMOBILIN –P 0.3

Intended Use

The separator plant is designed for the separation of saponifiable oils and fats of organic and animal origin exclusively

Unloading and Transport

Always carry the unit using sling ropes attached to lifting tabs. DO NOT lift the unit by the inlet or outlet pipes; this may damage the seal.

Installation

Prepare the pipes for connection. Align the unit by observing the flow direction markers. Slide over the push-fit coupling. Fill the separator with fresh water via inlet line or by opening the cap, until water flows out of separator outlet pipe.

CAUTION

In order to avoid the solidification of FAT in pipe line, length of pipeline from kitchen sink to separator inlet should not exceed 7.5m.

Disposal and Cleaning

Disconnect the separator unit from inlet and outlet by sliding back the push-fit coupling. Dispose the grease and sludge in accordance with local regulations. Clean the separator thoroughly using a high pressure water jet. Connect the separator back to inlet and outlet by sliding the push fit coupling. Fill the separator with fresh water via inlet line or by opening the cap, until water flows out of separator outlet.

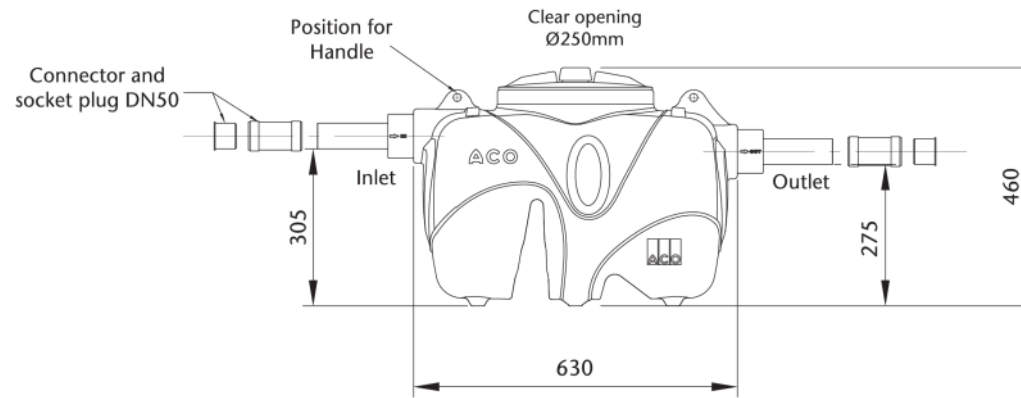

DATA SHEET

Nominal Capacity	0.3lps
Total Volume	36ltrs
Grease Volume	10ltrs
Sludge Volume	11ltrs
Weight (Empty)	7.6kg
Weight (Full)	55kg
Overall Width	380mm

CAUTION

Two persons should carry the unit using sling ropes attached to lifting tabs. DO NOT lift the unit by the inlet or outlet; this may damage the seal

For connection of 1 (one) commercial dishwasher with a minimum cleaning period of 1 min. at a turnover period of ½ minutes (cycle time $t = 1\frac{1}{2}$ min.)

Rinse water consumption of industrial dishwasher $v = 5$ l
In addition to the dishwasher, connecting no more than 1 device for pre-rinsing the dishes

